

ARTICULO: 2109B

Válvula de mariposa tipo wafer

Butterfly valve wafer type

Características

1. Válvula de mariposa tipo wafer.
2. Cuerpo de fundición EN-GJL-200 (GG-20) para montaje entre bridas ANSI 150 y EN 1092 PN 10/16.
3. Elastómero de NBR.
4. Disco de acero inoxidable 1.4408 (CF8M).
5. Brida montaje actuadores según ISO 5211.
6. Longitud entre caras según UNE EN 558-1 Serie 20 (DIN 3202 K1).
7. Recubrimiento con pintura Epoxi.
8. Temperatura de trabajo -20°C +110 °C.
9. Máxima presión de trabajo:
16 bar (medidas 2" a 12")
10 bar (medidas 14" a 24")

Features

1. Butterfly valve wafer type.
2. EN-GJL-200 (GG-20) CI body allows installation between ANSI 150 and EN 1092 PN 10/16 flanges.
3. NBR body seat.
4. Disc made of Stainless Steel 1.4408 (CF8M).
5. Actuator mounting plate according to ISO 5211.
6. Face to face according to UNE EN 558-1 Series 20 (DIN 3202 K1).
7. Epoxy coating.
8. Working Temperature -20°C +110 °C.
9. Maximum working pressure:
16 bar (sizes 2" to 12")
10 bar (sizes 14" to 24")

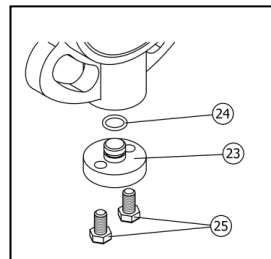
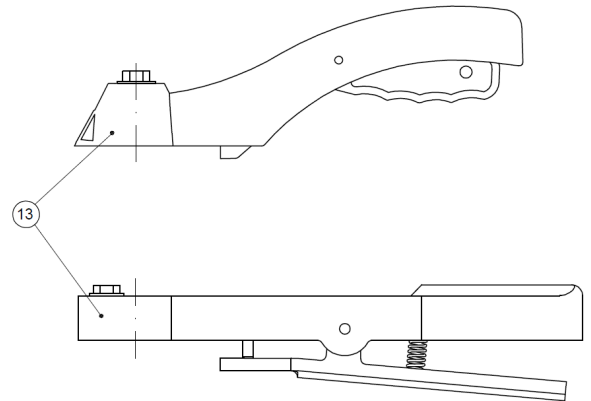
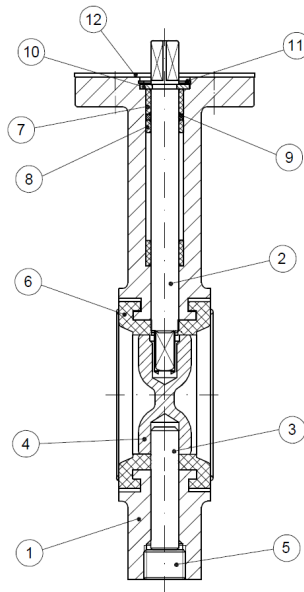

**Solamente /
Only ≥ 14"**

N.	Denominación / Name	Material	Acabado Superficial / Surface Treatment	Cód. Recambio Spare Part Code
1	Cuerpo / Body	Fundición / Cast Iron EN-GJL-200	Pintado Epoxi / Epoxy Painted	-----
2	Eje / Stem	Acero Inox. / Stainless Steel AISI 416	-----	-----
3	Pivote / Pivot	Acero Inox. / Stainless Steel AISI 416 ($\leq 12''$)	-----	-----
4	Disco / Disc	Acero Inox. / Stainless Steel 1.4408 (CF8M)	Granallado / Shot blasting	-----
5	Tapón / Plug	Acero Carbono / Carbon Steel ($\leq 12''$)	Cincado / Zinc Plated	-----
6*	Elastómero / Seat	NBR	-----	EB2109
7	Casquillo / Bush	PTFE + Grafito / Graphite	-----	-----
8	Casquillo / Bush	PTFE + Grafito / Graphite	-----	-----
9	Tórica / O' ring	NBR	-----	-----
10	Arandela / Washer	Acero Carbono / Carbon Steel	Cincado / Zinc Plated	-----
11	Seguro / Stop Ring	Acero Carbono / Carbon Steel	Cincado / Zinc Plated	-----
12	Placa dentada / Plate	Acero Carbono / Carbon Steel	Cincado / Zinc Plated	-----
13	Palanca / Handle	Aluminio o Fundición EN-GJL-200 / Aluminium or Cast iron EN-GJL-200	Pintado Epoxi / Epoxy Painted	-----
23	Tapón /	Fundición / Cast Iron EN-GJL-200 ($\geq 14''$)	Pintado Epoxi / Epoxy Painted	-----
24	Tórica / O'ring	NBR ($\geq 14''$)	-----	-----
25	Tornillo / Bolt	Acero Carbono / Carbon Steel ($\geq 14''$)	Cincado / Zinc Plated	-----

* Piezas de recambio disponibles / Available spare parts

DIMENSIONES GENERALES / GENERAL DIMENSIONS

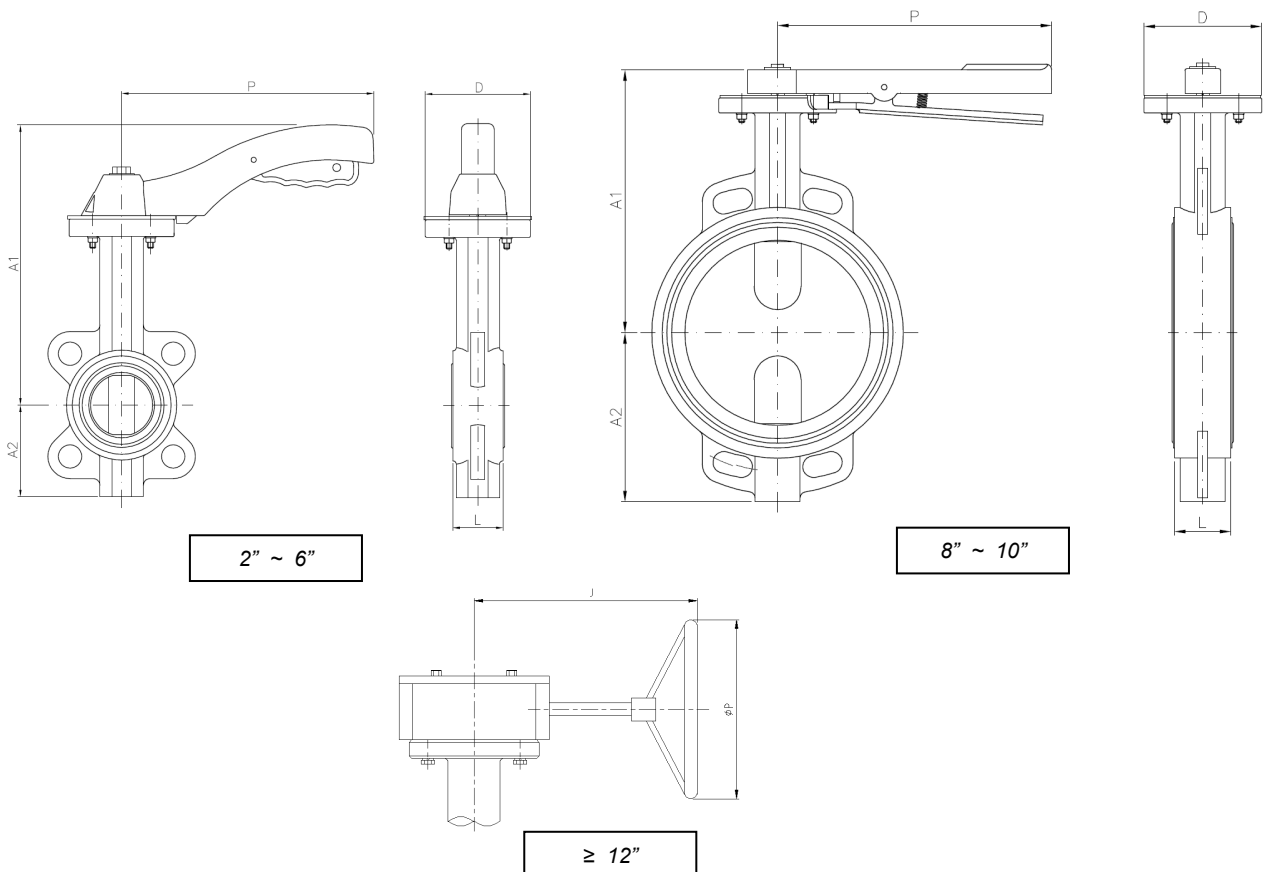

Ref.	Medida / Size	DN	PN	L	Dimensiones / Dimensions (mm)				Peso / Weight (kg)
					A1	A2	J	P	
2109B 09	2"	50	16	43	238	70	***	170	2,800
2109B 10	2 1/2"	65	16	46	238	80	***	170	3,300
2109B 11	3"	80	16	46	238	100	***	170	3,800
2109B 12	4"	100	16	52	270	115	***	215	5,800
2109B 13	5"	125	16	56	300	135	***	215	7,400
2109B 14	6"	150	16	56	300	150	***	215	8,350
2109B 16	8"	200	16	60	280	180	***	300	14,400
2109B 18	10"	250	16	68	330	215	***	300	21,800
2109B 20	12"	300	16	78	360	250	240	290	38,800
2109B 22	14"	350	10	78	390	260	257	290	56,100
2109B 24	16"	400	10	102	420	300	257	290	77,600
2109B 26	18"	450	10	114	445	330	306	400	115,500
2109B 28	20"	500	10	127	480	370	306	400	144,500
2109B 32	24"	600	10	152	710	467	342	400	243,000

*** Nota: De 2" a 6" Maneta de aluminio / From 2" to 6" Aluminium handle.
De 8" a 10" Maneta de fundición de hierro / From 8" to 10" cast iron handle.
A partir de 12" operación mediante reductor manual / From 12", handling by gear box.

Dimensiones de brida superior / Top flange dimensions:

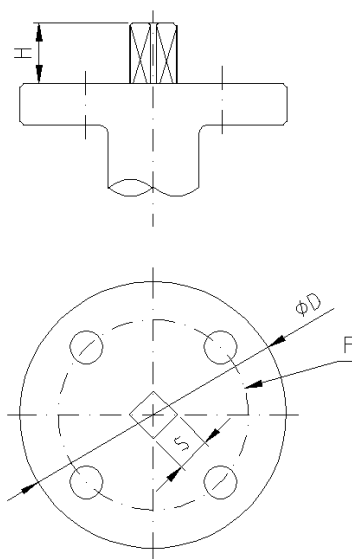

Top flange dimensions						
Article	DN	F (ISO5211)	S	D	H	Torque N·m
2109B 09	50	F05	11	65	16	15
2109B 10	65	F05	11	65	16	22
2109B 11	80	F05	11	65	16	30
2109B 12	100	F07	14	90	16	45
2109B 13	125	F07	14	90	16	66
2109B 14	150	F07	14	90	16	100
2109B 16	200	F07/F10	17	125	28	134
2109B 18	250	F10	22	125	28	220
2109B 20	300	F10/F12	22	150	28	270
2109B 22	350	F12	22	150	45	610
2109B 24	400	F14	27	175	45	805
2109B 26	450	F14	27	175	45	1100
2109B 28	500	F14	36	175	45	1500
2109B 32	600	F16	46	210	45	1900

Perdidas de Carga (Cv) según posición del disco / Head losses according to disc position:

DN	Posición del Disco (grados) / Disc Position (degrees)								
	90°	80°	70°	60°	50°	40°	30°	20°	10°
50	144	114	84	61	43	27	16	7	1
65	282	223	163	107	67	43	24	11	1.5
80	461	364	267	154	96	61	35	15	2
100	841	701	496	274	171	109	62	27	3
125	1376	1146	775	428	268	170	98	43	5
150	1850	1542	1025	567	354	225	129	56	6
200	3316	2842	1862	1081	680	421	241	102	12
250	5430	4525	2948	1710	1076	667	382	162	19
300	8077	6731	4393	2563	1594	1005	555	235	27
350	10538	8874	5939	3384	2149	1320	756	299	34
400	13966	11761	7867	4483	2847	1749	1001	397	45
450	17214	14496	10065	5736	3643	2237	1281	507	58
500	22339	18812	12535	7144	4536	2786	1595	632	72
600	43116	39236	26157	16528	9989	5605	2587	1222	150

VALORES DE Cv / Cv VALUES

Cv = Es la cantidad de galones por minuto (gpm) que pasará a través de la válvula generando una pérdida de carga de 1 psi.

Cv = The flow rate of water (g.p.m.) which generates a pressure drop of 1 psi across the valve.

Medidas de Precaución para instalación / Caution measures for Installation:

1. No instale la válvula en posición totalmente cerrada / *Do not install the butterfly valve in total closed position.*
2. Verifique el buen paralelismo de las bridas / *Check the good parallelism of the flanges.*
3. No coloque otras juntas entre las bridas / *Do not insert other gaskets between flange and valve.*

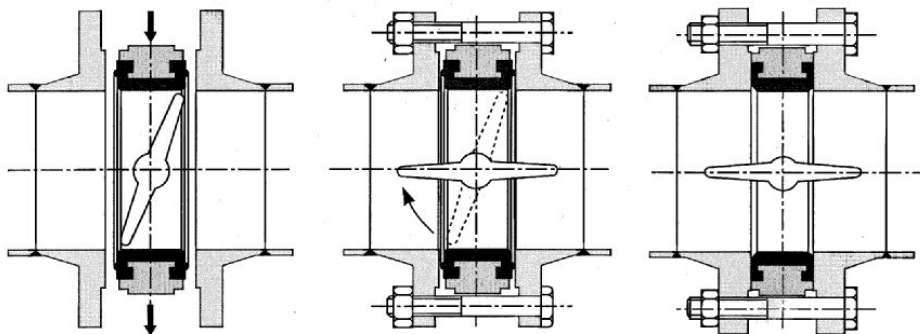

CURVA PRESION TEMPERATURA / *PRESSURE TEMPERATURE RATING*

