

# MIXIT

All-in-one mixing loop



<b>1. Mixing loops made simple</b> . . . . .	<b>4</b>	<b>7. Installation</b> . . . . .	<b>47</b>
Features . . . . .	5	Insulating shells . . . . .	47
Temperature control . . . . .	5	Electrical installation . . . . .	47
Controlling MIXIT . . . . .	5	Orientation of the B port. . . . .	48
Applications . . . . .	5	Terminal connections overview . . . . .	49
<b>2. Performance range</b> . . . . .	<b>6</b>	<b>8. Operating the product</b> . . . . .	<b>50</b>
Compatible pumps . . . . .	7	Operating panel for MIXIT . . . . .	50
Multi-pump mode . . . . .	7	Starting up the system. . . . .	51
Performance curves . . . . .	8	Temporary heating . . . . .	53
<b>3. Guide to selection and sizing</b> . . . . .	<b>14</b>	Setting up MIXIT using Grundfos GO Remote. . . . .	53
Valve selection using performance range curves . . . . .	14	Warnings and alarms. . . . .	53
Valve sizing based on calculations . . . . .	14	Firmware updates . . . . .	53
Sizing tool for MIXIT . . . . .	14	<b>9. Operating conditions</b> . . . . .	<b>54</b>
Step-by-step valve sizing guide. . . . .	15	Location . . . . .	54
<b>4. System applications</b> . . . . .	<b>17</b>	Maximum distance between MIXIT and the pump. . . . .	54
System integration . . . . .	17	Minimum space . . . . .	54
Distribution circuits . . . . .	17	Ambient conditions . . . . .	54
MIXIT in a radiator heating system . . . . .	21	Maximum operating pressure . . . . .	54
MIXIT in an underfloor heating system. . . . .	23	Pumped liquids. . . . .	54
MIXIT in an air handling unit system . . . . .	25	Radio communication . . . . .	54
MIXIT in a cooling system . . . . .	28	<b>10. Technical data</b> . . . . .	<b>55</b>
MIXIT in a combined system (heating and cooling) . . . . .	30	Type key . . . . .	55
<b>5. Components</b> . . . . .	<b>32</b>	Cable requirements. . . . .	55
Ball valve . . . . .	34	Electrical data. . . . .	55
Non-return valve . . . . .	35	Inputs and outputs . . . . .	55
Seats . . . . .	35	Classes . . . . .	56
Sensors . . . . .	35	Sound pressure level. . . . .	56
<b>6. Functions overview</b> . . . . .	<b>36</b>	Actuator. . . . .	56
MIXIT variants and upgrades . . . . .	37	Sensor data . . . . .	57
Temperature controller. . . . .	38	Valve . . . . .	59
Underfloor overheat protection . . . . .	39	<b>11. Dimensions</b> . . . . .	<b>62</b>
Heating coil preheat and frost protection . . . . .	39	<b>12. Accessories</b> . . . . .	<b>65</b>
Frost protection for cooling. . . . .	39	Insulating shells . . . . .	65
Frost protection for combined heating and cooling . . . . .	39	Non-return valve . . . . .	65
Pump control modes . . . . .	39	Temperature protection switch . . . . .	65
Position control. . . . .	40	Temperature sensor . . . . .	65
Weather curve . . . . .	40	Outdoor temperature sensors . . . . .	65
Eco schedule . . . . .	40	Thread-thread adapters . . . . .	66
Warm weather shutdown . . . . .	40	Thread-flange adapters . . . . .	67
Pressure independence. . . . .	41	Flange-flange adapters . . . . .	68
Supply flow limit . . . . .	41	<b>13. Product numbers</b> . . . . .	<b>70</b>
Return temperature limit . . . . .	41	MIXIT valve unit . . . . .	70
Thermal power limit. . . . .	41	Upgrades . . . . .	70
Differential temperature limit. . . . .	41	MAGNA3 single-head pumps . . . . .	71
Supply source setpoint . . . . .	42	MAGNA3 twin-head pumps . . . . .	71
Energy monitoring. . . . .	44	MAGNA3 single-head pumps for the German market. . . . .	72
Grundfos BuildingConnect . . . . .	46	MAGNA3 twin-head pumps for the German market. . . . .	72
Fieldbus integration. . . . .	46	TPE3 single-head pumps. . . . .	73

TPE3 twin-head pumps . . . . . 73

**14. Technical terms . . . . . 74**

**15. Grundfos Product Center . . . . . 76**

**16. Document quality feedback. . . . . 77**

## 1. Mixing loops made simple

Grundfos MIXIT is an all-in-one mixing loop for heating and cooling systems.

MIXIT is controlled by a built-in actuator and controller and it offers the following:

- a uniquely designed valve for precise flow-temperature control due to real-time sensor measurements, even at low flow, ensuring stable control
- modified equal percentage characteristic for linear heat power regulation
- easy setup and a completely integrated temperature control solution tailored to your specific application
- flexible offerings in both applications, and features designed to accommodate your needs
- one connection for all data points on the system, pump and MIXIT unit.

### A complete mixing loop with only two components

With MIXIT the complexity of the traditional mixing loop is vastly reduced, as MIXIT allows you to build a complete mixing loop with only two components:

1. MIXIT, a highly intelligent valve unit with integrated non-return valve (threaded versions), actuator and sensors
2. MAGNA3, a best-in-class circulator pump or TPE3, single-stage pump.

This makes designing, installing and operating mixing loops incredibly simple and easy. Also, because MIXIT is designed to communicate with the MAGNA3/TPE3 pump via Grundfos GLoWPAN radio signal, no additional wiring or control unit is needed.

In traditional mixing loops, the components needed for a mixing loop are supplied from different vendors. With MIXIT you get single point of warranty and competent technical support for the entire MIXIT system.

### Traditional mixing loop vs. the MIXIT system

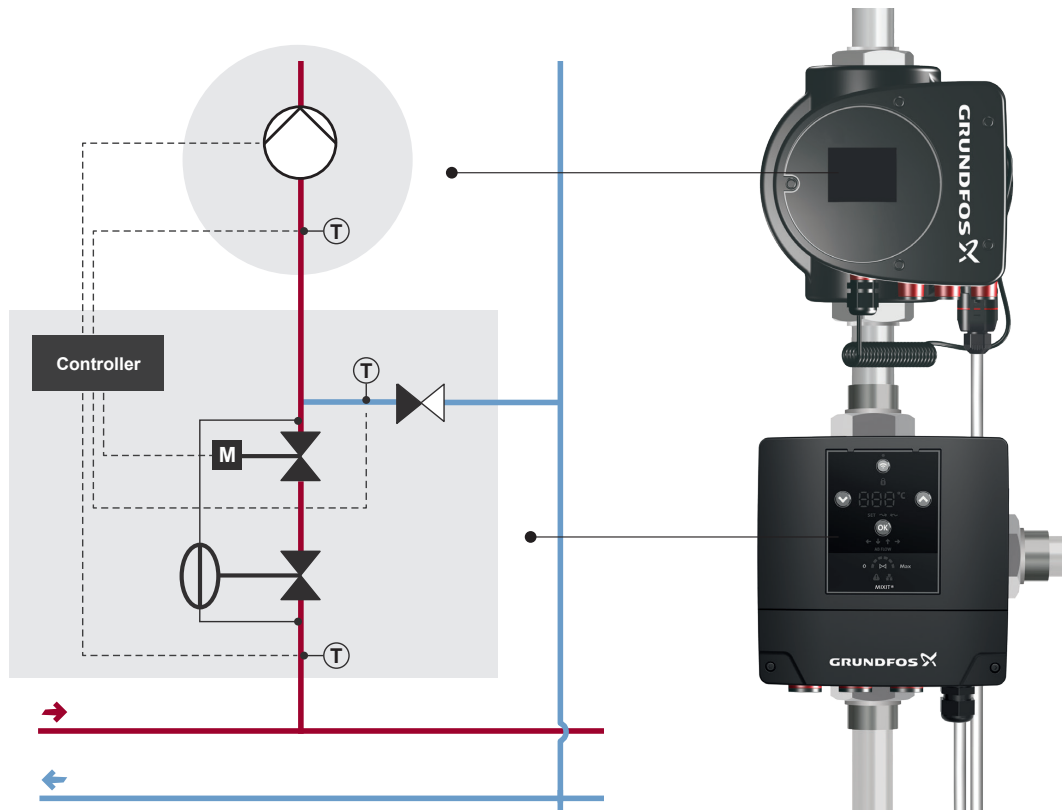

Left: Traditional setup. Right: MIXIT system.

TM071467

## Features

- All-in-one, plug-and-play solution eliminating any uncertainties found in a traditional mixing-loop setup.
- Integrated actuator and controller.
- Built-in temperature and flow sensors.
- Pressure independent control valve with balancing function.
- Integrated, removable non-return valve in threaded versions.
- Valve and pump settings to match your application, ensuring a more effective application control.
- Fast and simple installation and setup.
- Intuitive and simple operating panel.
- Easy configuration with the Grundfos GO Remote app.
- Built-in fieldbus (BACnet and Modbus) for easy integration into building management systems (BMS).
- Insulating shells for heating systems according to ENeV supplied with the product.

As MIXIT is a pre-fabricated, complete mixing loop with integrated control functions, only two power cables are required for the MIXIT system to work. The compact design ensures a maximum utilisation of space and a tidy and compact installation.

The MIXIT system can operate as follows:

- as a standalone mixing loop in buildings without any additional equipment
- as a subsystem in larger building controlled by a BMS system.

## Temperature control

The built-in temperature control controls the secondary flow temperature. The controller adjusts the position of the valve according to the setpoint and measured temperatures, and it acts according to the application. The setpoint can be set on the operating panel, in Grundfos GO Remote or via fieldbus.

In radiator and underfloor heating systems the controller will control the mixed flow temperature.

In heating-coil applications it will control the air temperature leaving the heating coil. To measure the air temperature, you can either install a temperature sensor available as an accessory, or have the temperature data sent via fieldbus.

In cooling as well as combined heating and cooling applications, the controller will control the mixed flow temperature.

### Related information

[Temperature sensor](#)

## Controlling MIXIT

Setting up and controlling a mixing loop have never been easier. This is done via MIXIT's operating panel and Grundfos GO Remote. With Grundfos GO Remote you can do the following:

- Configure whether MIXIT must operate as a two- or three-way valve.
- Define the application type, allowing you to activate settings, which are typically found beneficial in the given system.
- Set standard functions such as weather curve, supply source setpoint, temperature control and position control.
- Set balancing functions such as primary flow, thermal power limit, return temperature limit, differential temperature limit and monitor the energy consumption (upgrade required).
- Schedule an operating pattern and set warm-weather shutdown.
- Monitor the operating status.
- Unlock and download upgrades.

Via wireless communication, the MIXIT valve unit takes control over the pump, which means that no additional wiring between MIXIT and the pump is needed.

## Applications

MIXIT is a control valve with actuator and built-in temperature control.

Besides a control valve, MIXIT also includes sensors. A non-return valve is factory fitted on the threaded versions of MIXIT for optional use. The actuator is incorporated in a control box together with a control unit which controls both the actuator and the pump.

MIXIT can be used in mixing loops in all heating and cooling systems where there is a need to control the flow temperature, such as radiator heating, underfloor heating, air handling units, cooling applications as well as combined heating and cooling applications.

MIXIT is perfect for new installations or complete renovations in commercial buildings as replacement for traditional mixing loops.

MIXIT can either operate as a stand-alone system or as a subsystem in installations controlled by a BMS system.

## Intended use in the United Kingdom

Safety precautions for UK:



The product is not intended for use in any home appliance, home automation, home control system or consumer product in the UK.

## 2. Performance range

MIXIT	B-port orientation	Connection	G [inch]	PN	K <sub>vs</sub> value, A and B port [m <sup>3</sup> /h] <sup>1)</sup>	Minimum settable flow limit [m <sup>3</sup> /h] <sup>2)</sup>
DN 25-6.3	Left	Threaded	G 1 1/2	PN 10	6.3	0.3
DN 25-6.3	Right	Threaded	G 1 1/2	PN 10	6.3	0.3
DN 25-10	Left	Threaded	G 1 1/2	PN 10	10	0.5
DN 25-10	Right	Threaded	G 1 1/2	PN 10	10	0.5
DN 32-16	Left	Threaded	G 2	PN 10	16	0.8
DN 32-16	Right	Threaded	G 2	PN 10	16	0.8
DN 32-16	Left	Flange		PN 6/10	16	0.8
DN 32-16	Right	Flange		PN 6/10	16	0.8
DN 40-25	Left	Flange		PN 6/10	25	1.3
DN 40-25	Right	Flange		PN 6/10	25	1.3
DN 50-40	Left	Flange		PN 6/10	40	2
DN 50-40	Right	Flange		PN 6/10	40	2

<sup>1)</sup> The K<sub>vs</sub> value represents the water in m<sup>3</sup>/h at a differential pressure of 1 bar from port A to AB.

<sup>2)</sup> The DYNAMIC upgrade is required to set a flow limit.

### Orientation of the B port

All MIXIT valve units are available with either a right-oriented B port or a left-oriented B port.

### Related information

- [3. Guide to selection and sizing](#)
- [Step-by-step valve sizing guide](#)
- [Supply flow limit](#)
- [Orientation of the B port](#)
- [13. Product numbers](#)

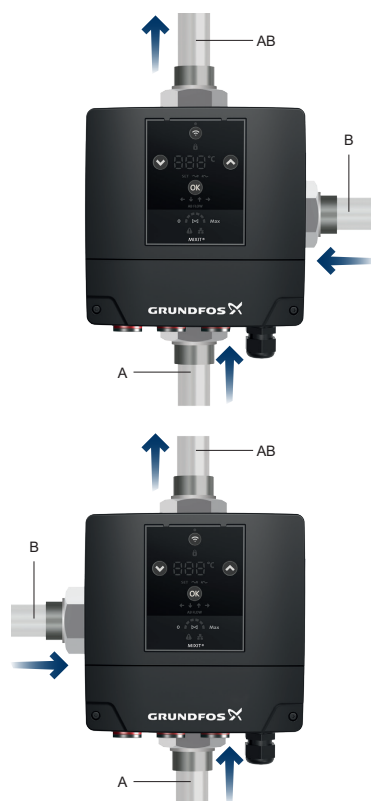

TM071426

Right-oriented B port (top) and left-oriented B port (bottom). The arrows indicate the direction of the supply flow.

## Compatible pumps

The pump size best suited for your application is determined based on the desired secondary flow and pressure drop in the load.

MIXIT is compatible with the following Grundfos pumps:

- MAGNA3 single-head pumps with production code from 4319 (WWYY) and onwards. That is, pump models D, E and onwards.
- MAGNA3 D twin-head pumps with production code from 4319 (WWYY) and onwards. That is, pump models D, E and onwards.
- TPE3 single-head pumps.
- TPE3 D twin-head pumps.

MIXIT is typically coupled with the pump variants listed below.

### MAGNA3 single-head pumps

- 25-40/60/80/100/120
- 32-40/60/80/100/120
- 32-40/60/80/100/120 F
- 40-40/60/80/100/120/150/180 F
- 50-40/60/80/100/120/150/180 F
- 65-40/60/80/100/120/150 F

### MAGNA3 twin-head pumps

- 32-40/60/80/100
- 32-40/60/80/100/120 F
- 40-40/60/80/100/120/150/180 F
- 50-40/60/80/100/120/150/180 F
- 65-40/60/80/100/120/150 F

### TPE3 single-head pumps

- 32-80/120/150/180/200 F
- 40-80/120/150/180/200/240 F
- 50-60/80/120/150/180/200/240 F
- 65-60/80/120/150/180/200 F

### TPE3 twin-head pumps

- 32-80/120/150/180/200 F
- 40-80/120/150/180/200/240 F
- 50-60/80/120/150/180/200/240 F
- 65-60/80/120/150/180/200 F

### Related information

[13. Product numbers](#)

## Multi-pump mode

MIXIT supports pumps operating with the multi-pump function enabled for control of:

- single-head pumps connected in parallel
- twin-head pumps without the use of external controllers.

The multi-pump function is set up via a selected pump or master pump, and this setup is done before connecting MIXIT to the system.

## Performance curves

The following figures show the flow characteristics and performance ranges of the MIXIT variants and applicable pumps, which can be used as guidance for sizing and selecting your MIXIT system.

### Settable flow range

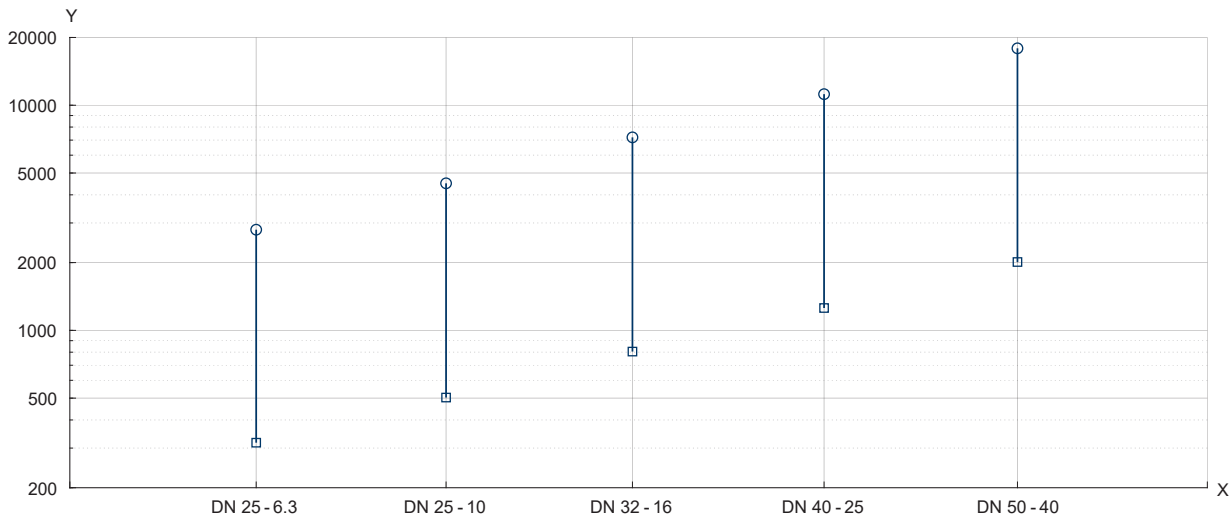

TM071488

Settable flow range for MIXIT operating as a pressure independent, balancing, two-way valve at  $\Delta p_{v100} = 20 \text{ kPa}$

Axis	Value
Y	Primary flow, Q [l/h]
X	MIXIT variant

The graph shows the settable flow range for MIXIT operating as a pressure independent, balancing, two-way valve.

Maximum flow is given for a  $\Delta p_{v100} = 20 \text{ kPa}$ .

Two-way valve

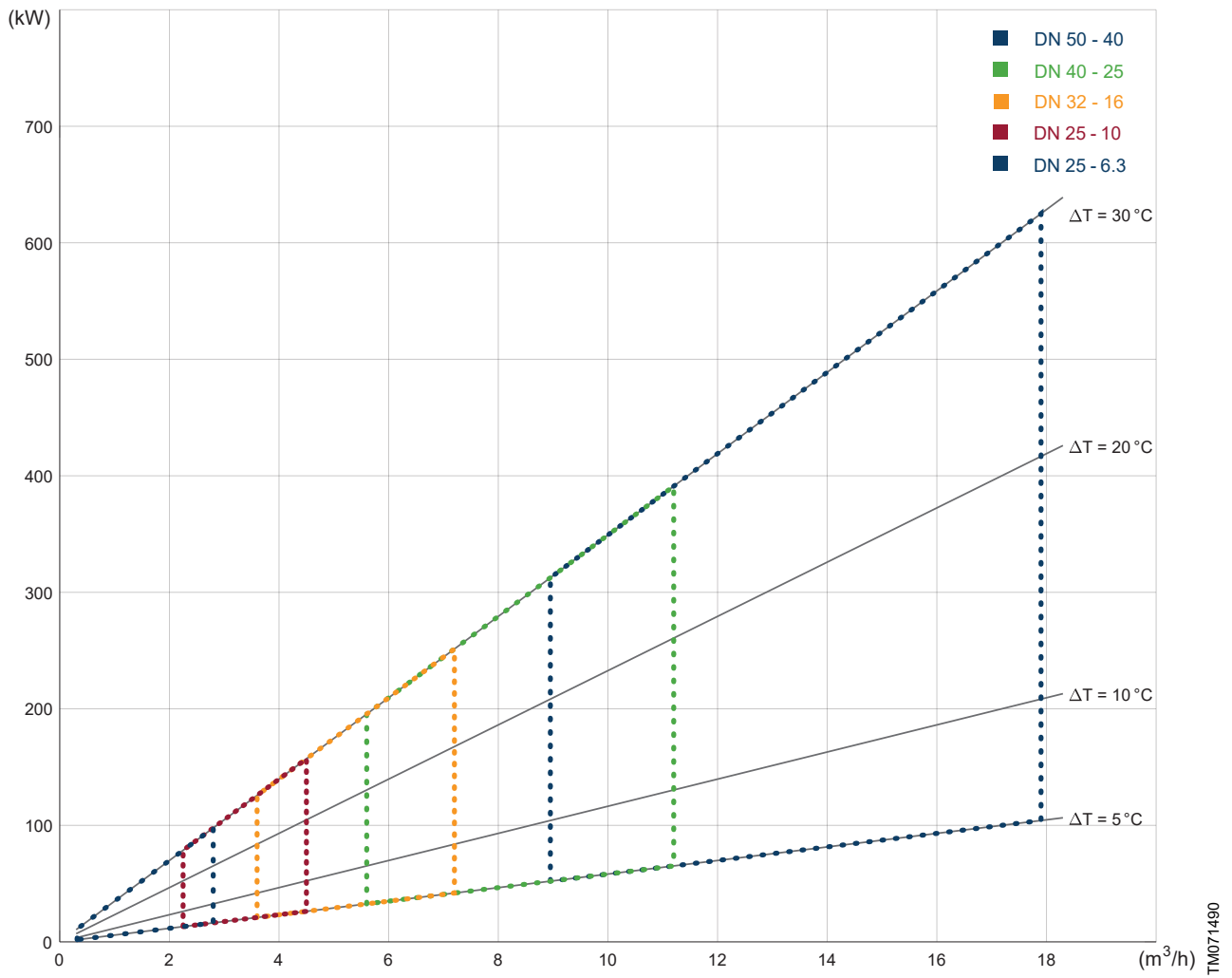

Performance range for two-way MIXIT valve at  $\Delta p_{v100} = 20 \text{ kPa}$

Axis	Value
Y	Heating/cooling load, $\Phi$ [kW]
X	Secondary flow, $Q_s$ [m <sup>3</sup> /h]

The figure shows the relationship between flow and heating/cooling load at various values of  $\Delta T$ . The stippled, coloured areas indicate the range of each available valve size.

## Three-way valve

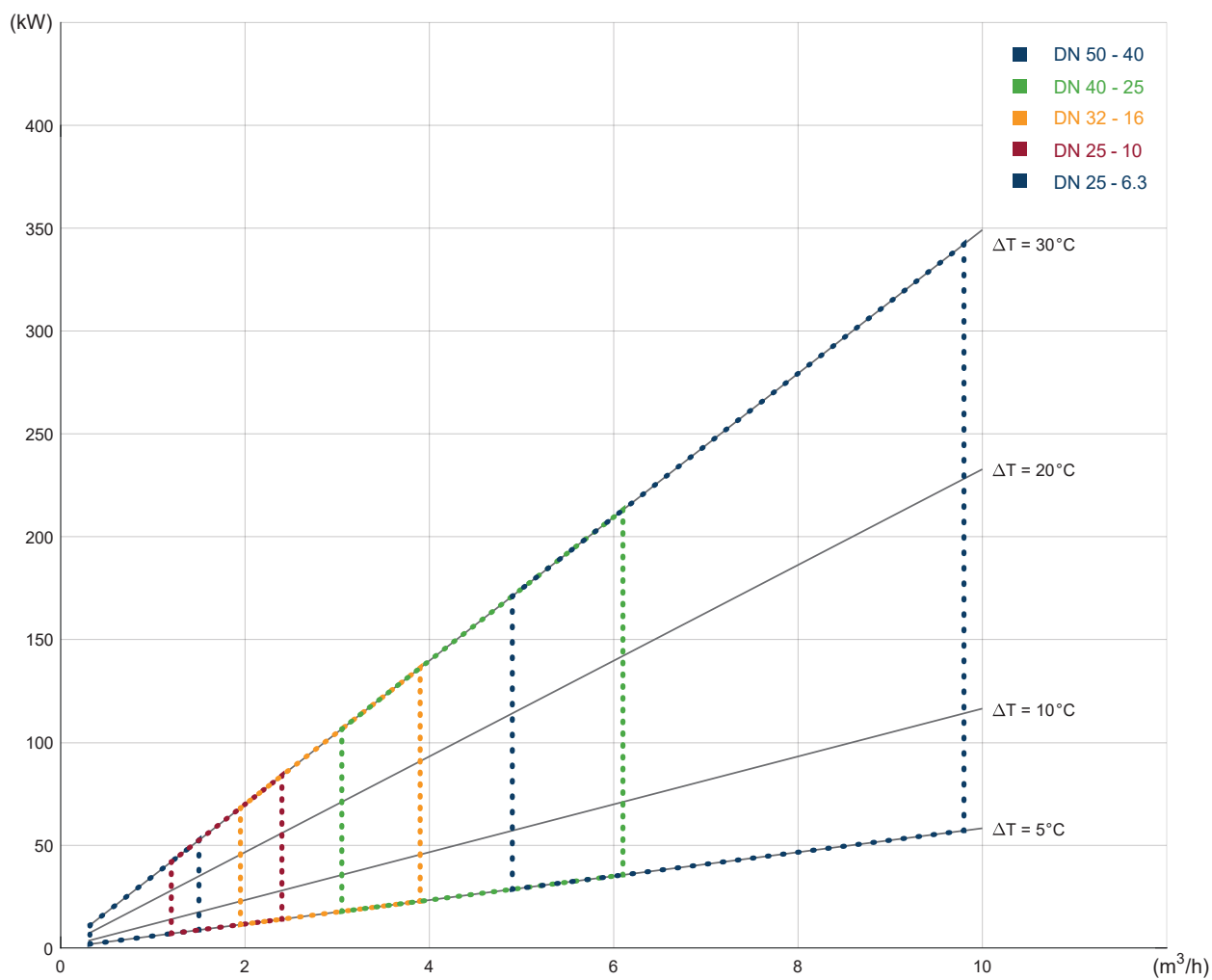

TM071489

Performance range for three-way MIXIT valve at  $\Delta p_{v100} = 6 \text{ kPa}$

Axis	Value
Y	Heating/cooling load, $\Phi$ [kW]
X	Secondary flow, $Q_s$ [m <sup>3</sup> /h]

The figure shows the relationship between flow and heat load at various values of  $\Delta T$ . The stippled, coloured areas indicate the range of each available valve size.

**MAGNA3 and MAGNA3 D performance range**

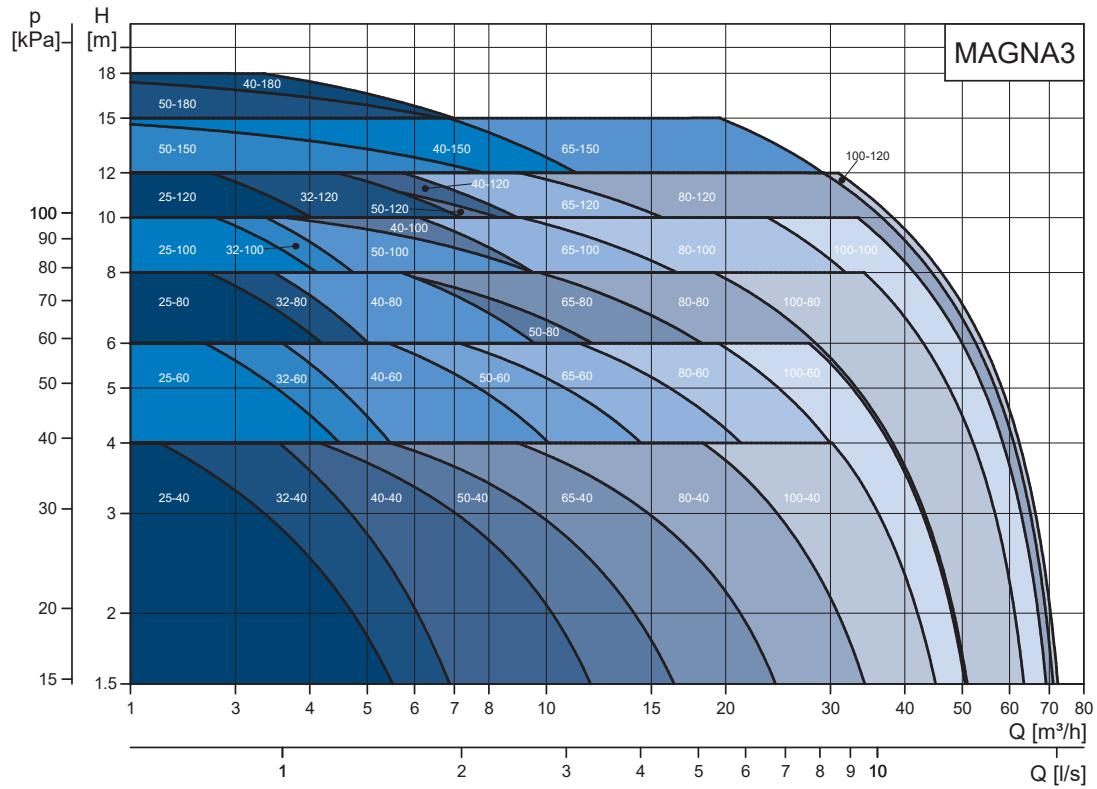

TM057963

*MAGNA3 single-head pump*

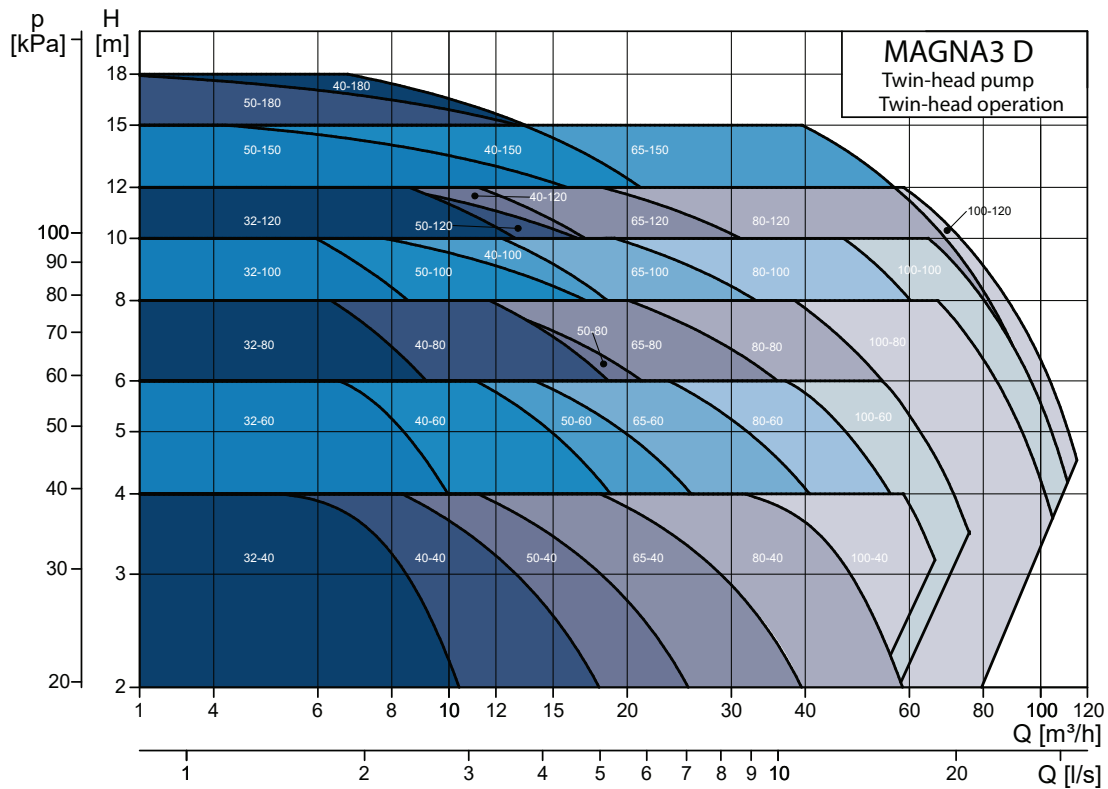

TM053938

*MAGNA3 D twin-head pump in twin-head operation*

TPE3 and TPE3 D performance range

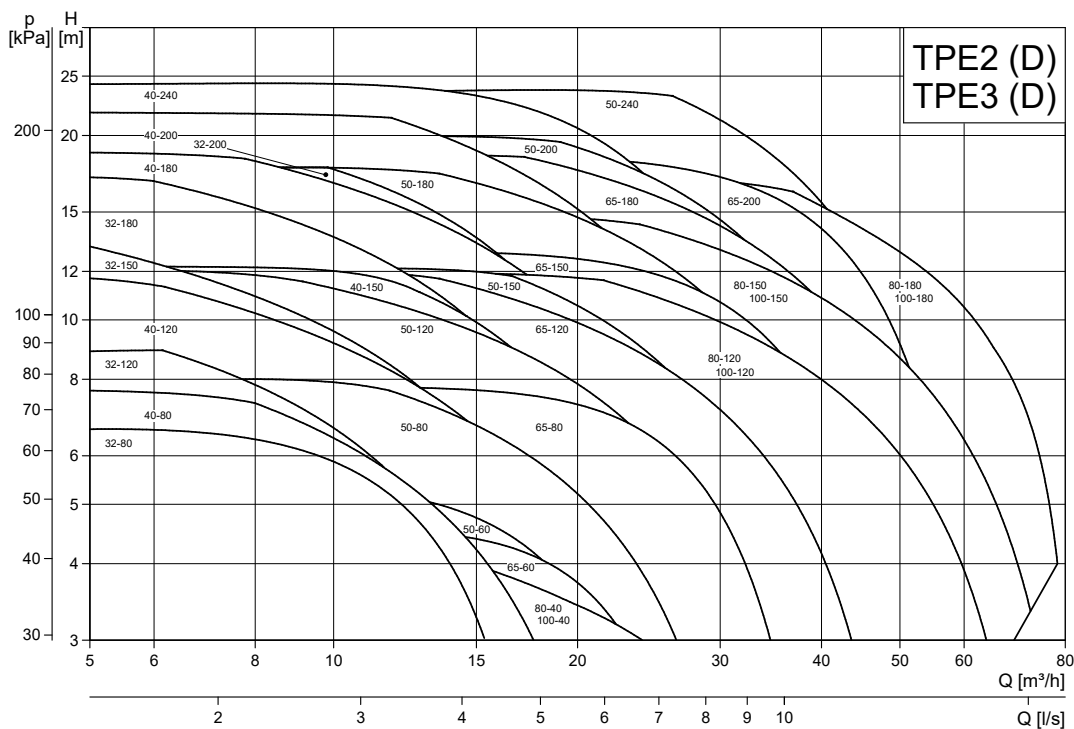

TM058177

TPE3 single-head pump

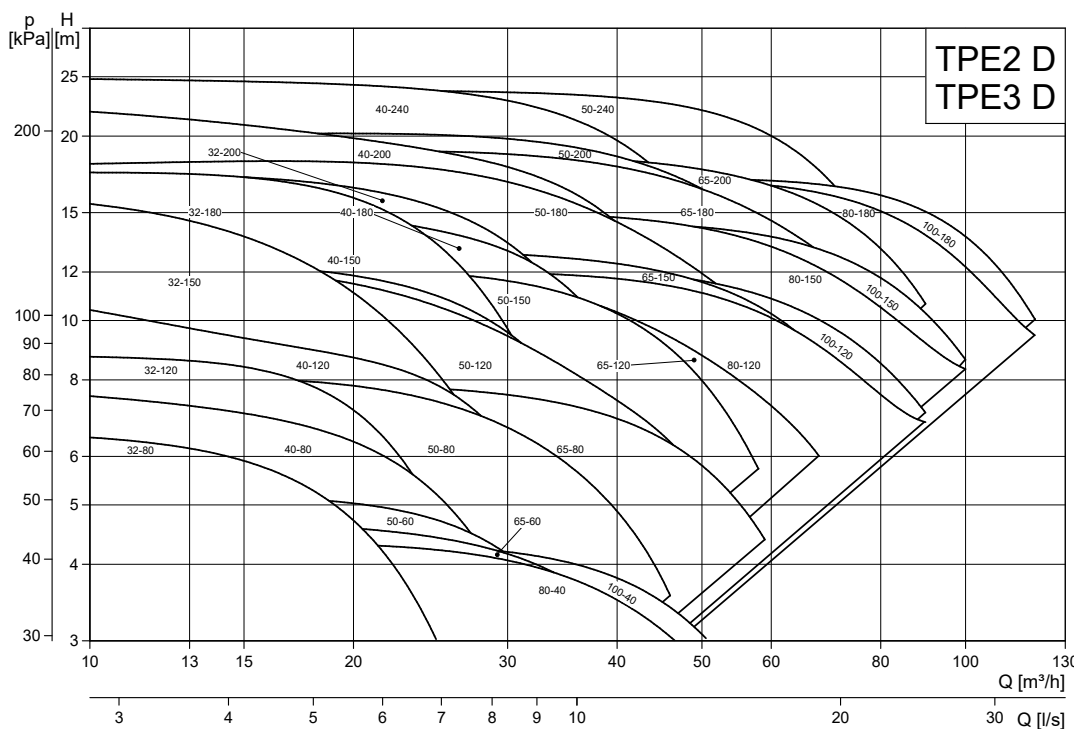

TM058198

TPE3 D twin-head pump in twin-head operation

**Related information**

*Valve selection using performance range curves*

*Step-by-step valve sizing guide*

## 3. Guide to selection and sizing

In order to select the optimal valve and pump size, you need to determine the required valve capacity and flow rate for your system.

### Selecting the correct pump size

When you have sized the valve, you can select the appropriate pump size based on the desired secondary flow and the head required to overcome secondary side head losses.

MAGNA3 and TPE3 pumps are applicable for MIXIT. For further information, see the performance range section and compatible pumps section.

### Related information

[2. Performance range](#)

### Valve selection using performance range curves

MIXIT performance range curves offer a simple selection tool, provided that the pressure differential across the fully open valve in your application matches one of these performance range curves:

Two-way valve with pressure differential  $\Delta p_{v100} = 20$  [kPa]

Three-way valve with pressure differential  $\Delta p_{v100} = 6$  [kPa]

- Determine two out of three of these parameters:
  - heating/cooling load  $\Phi_s$  [kW]
  - secondary flow  $Q_s$  [m<sup>3</sup>/h].
  - secondary temperature difference  $\Delta T_s$ .

If you need to calculate some of the parameters above, see the step-by-step valve sizing guide.

- You can go to the relevant performance range curve and select the MIXIT variant that matches your application. See the section on performance curves.

### Related information

[Performance curves](#)

[Step-by-step valve sizing guide](#)

### Valve sizing based on calculations

The most accurate way to size the valve is to calculate the required valve capacity for your system design flow and match it with the equivalent  $K_{Vs}$  from our performance range.

#### $K_v$

$K_v$  represents the valve capacity measured as the flow of water in m<sup>3</sup>/h at a pressure differential of 1 bar across the valve, with the valve open at any position.

#### $K_{Vs}$

$K_{Vs}$  is the maximum  $K_v$  value measured when the valve is fully open (100%).

For MIXIT,  $K_{Vs}$  is measured from port A to AB.

- Use the step-by-step guide below to determine the required valve capacity  $K_v$  for your system design. See the step-by-step valve sizing guide.
- Go to the performance range table and select a valve within the  $K_{Vs}$  value range that matches the calculated  $K_v$  value. See the section on performance range.

### Related information

[Step-by-step valve sizing guide](#)

### Sizing tool for MIXIT

Use the following link for sizing the MIXIT product.

<https://www.grundfos.com/campaign/mixit-sizing.html>

## Step-by-step valve sizing guide

The table below shows examples of applications and parameters used for calculating the correct valve size.

	Example 1 Injection circuit with a two-way valve	Example 2 Mixing circuit with a three-way valve
<p>Primary side:</p> <p><math>\Phi_p</math>: Load [kW]</p> <p><math>Q_p</math>: Primary flow [m<sup>3</sup>/h]</p> <p><math>T_p</math>: Supply temperature [°C]</p> <p><math>T_r</math>: Return temperature [°C]</p> <p>Secondary side:</p> <p><math>\Phi_s</math>: Load [kW]</p> <p><math>Q_s</math>: Secondary flow [m<sup>3</sup>/h]</p> <p><math>T_s</math>: Forward temperature [°C]</p> <p><math>T_r</math>: Return temperature [°C]</p> <p><math>\Delta p_v</math>: Pressure differential across the valve [kPa]</p>		
<p><b>1. Known parameters</b></p> <p>If the load (thermal output power) of your building is unknown, you can estimate the load by multiplying the building class [W/m<sup>2</sup>] and the area of the building [m<sup>2</sup>].</p> <p>When the ratio between the primary and secondary <math>\Delta T</math> is larger than 6, we recommend that you use an external bypass.</p> <p>Note that the parameters in the examples are not selected on the basis of the circuit type and that they are interchangeable.</p>	<p><math>\Phi_s = 200</math> [kW]</p> <p><math>T_p = 70</math> [°C]</p> <p><math>T_s = 40</math> [°C]</p> <p><math>T_r = 30</math> [°C]</p>	<p><math>Q_s = 3.5</math> [m<sup>3</sup>/h]</p> <p><math>T_p = 70</math> [°C]</p> <p><math>T_s = 60</math> [°C]</p> <p><math>T_r = 40</math> [°C]</p>
<p><b>2. Calculate the required secondary flow</b></p> <p><math>Q_s = 0.86 \frac{\Phi}{\Delta T_s}</math></p> <p>The constant 0.86 is derived from the density and heat capacity of water and the correlation between seconds and hours.</p>	<p><math>Q_s = 0.86 \frac{200}{(40 - 30)} Q_s = 17.2</math> [m<sup>3</sup>/h]</p>	<p><math>\Phi_s = \frac{3.5(60 - 40)}{0.86} \Phi_s = 81</math> [kW]</p>
<p><b>3. Calculate the primary flow</b></p> <p><math>Q_p = Q_s \frac{\Delta T_s}{\Delta T_p}</math></p>	<p><math>Q_p = 17.2 \frac{(40 - 30)}{(70 - 30)}</math></p> <p><math>Q_p = 4.3</math> [m<sup>3</sup>/h]</p>	<p><math>Q_p = 3.5 \frac{(60 - 40)}{(70 - 40)}</math></p> <p><math>Q_p = 2.3</math> [m<sup>3</sup>/h]</p>
<p><b>4. Choose sizing method</b></p>		
<p><b>4A. Calculating <math>K_v</math></b></p>	<p>Follow the steps below to calculate the required valve capacity <math>K_v</math>.</p>	<p>Follow the steps below to calculate the required valve capacity <math>K_v</math>.</p>
<p><b>4A.1 Determine the pressure differential</b></p> <p><math>\Delta p_{v100}</math> = required pressure drop across the fully open valve.</p> <p>Typical design pressure drop:</p> <ul style="list-style-type: none"> <li>Two-way valve in pressurised distribution system: <math>\Delta p_{v100} = 10</math> kPa (typical value)</li> <li>Three-way valve in pressure-less system: <math>\Delta p_{v100} = 6-8</math> kPa. (Sized by <math>K_{vs}</math> value)</li> </ul>	<p>Example:</p> <p><math>\Delta p_{v100} = 10</math> [kPa]</p>	<p>Example:</p> <p><math>\Delta p_{v100} = 6</math> [kPa]</p>

	Example 1 Injection circuit with a two-way valve	Example 2 Mixing circuit with a three-way valve
<b>4A.2 Calculate the required valve capacity <math>K_v</math> in <math>m^3/h</math></b> $K_v = \frac{Q_p}{\sqrt{\frac{\Delta p_{v100}}{100}}}$	$K_v = \frac{4.3}{\sqrt{\frac{10}{100}}}$ $K_v = 13.6 [m^3/h]$	$K_v = \frac{2.3}{\sqrt{\frac{6}{100}}}$ $K_v = 9.4 [m^3/h]$
<b>4A.3 Select valve</b> Go to the performance range table and select a valve within a $K_{vs}$ range that matches your calculated $K_v$ value. Select the closest match, which provides the most economical valve that ensures sufficient valve authority. See the table in the section on performance range. When MIXIT is installed, you can control the valve position via Grundfos GO Remote to match the required pressure differential $K_v$ for your system design.	MIXIT DN 32-16: $K_{vs}$ value: 1.6 - 16 [ $m^3/h$ ] Flow range: 0.8 - 8.8 [ $m^3/h$ ]	MIXIT DN 25-10: $K_{vs}$ value: 1 - 10 [ $m^3/h$ ] Flow range: 0.5 - 5.5 [ $m^3/h$ ]
<b>4B. Settable flow range graph</b> Use the settable flow range graph to size and select your MIXIT variant. See the graph in the section on performance curves. Typical design pressure drop: <ul style="list-style-type: none"> <li>Pressure independent valves: <math>\Delta p_{v100} = 15-25</math> kPa. (Sized by flow). Please note that MIXIT does not require any minimum pressure differential to function as a pressure independent valve.</li> </ul>	Valid for pressure independent two-way valves with balancing and with a pressure differential $\Delta p_{v100}$ equal to 20 [kPa]. Example: Flow $Q_p = 4.3 [m^3/h] = 4300 [l/h]$ Selection via settable flow range graph: MIXIT DN 25-10 Flow range: up to 4500 [l/h] When MIXIT is installed, you can control the valve position via Grundfos GO Remote and set the flow limit to match the required pressure differential $K_v$ for your system design.	Not applicable for three-way valves.

## Related information

[2. Performance range](#)

[Performance curves](#)

[Valve selection using performance range curves](#)

[Valve sizing based on calculations](#)

## 4. System applications

Mixing loops are used whenever there is a need for controlling the flow temperature. The basic principle is to mix the primary water with the return water to obtain the required mixed flow temperature. When it comes to MIXIT, it can be used in HVAC systems with the following types of consumers:

- Radiator heating
- Underfloor heating
- Air handling unit
- General cooling units
- Combined units (Cooling & heating)

When applied to a primary distribution circuit, the heating system acts as a secondary circuit. In a temperature-controlled circuit, different types of mixing circuits are used. MIXIT can be applied to the following three circuit types working either as a two- or three-way valve:

### Pressurised distribution circuits

- Injection circuit with a two-way valve
- Injection circuit with a three-way valve

### Non-pressurised distribution circuit

- Mixing circuit with a three-way valve.

## System integration

Thanks to the integrated fieldbus, MIXIT can be incorporated into any building management system (BMS) using the RS485 terminal or ethernet port.

### RS485

- BACnet MS/TP protocol
- Modbus RTU protocol.

### Ethernet

- BACnet IP protocol
- Modbus TCP protocol
- Grundfos BuildingConnect.

### Related information

[Fieldbus integration](#)

[Setting up MIXIT using Grundfos GO Remote](#)

## Distribution circuits

### Injection circuit with a two-way valve - heating system

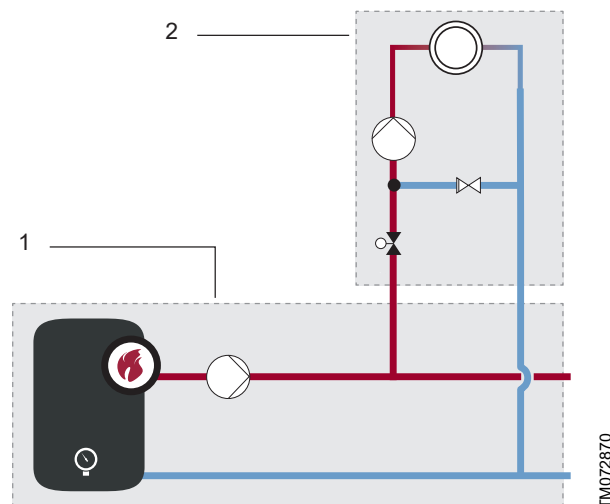

Pos.	Description
1	Primary system
2	Secondary system

This type of mixing circuit is the most common one in all new installations.

The injection circuit operates with a variable flow on the primary side (1) and a constant flow on the secondary side (2).

Hot water is injected through a two-way valve into the secondary system (2) by opening the valve. On the secondary side (2), cold water from the return pipe is mixed in through a bypass. The more water injected from the primary side (1), the less water is flowing through the bypass, resulting in a constant flow with a variable temperature at the load.

Because the bypass acts as a hydraulic short circuit, the pump in the secondary system (2) is not able to pump the water into the primary circuit. Therefore, this type of circuit is always pressurised in the primary system (1).

### Injection circuit with a two-way valve - Cooling system

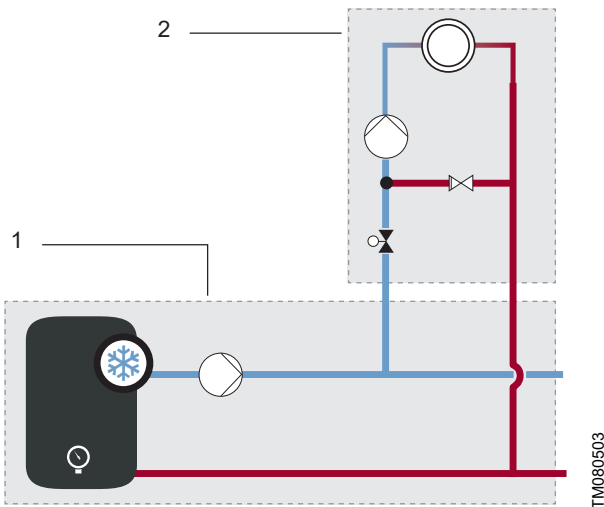

TM080503

Pos.	Description
1	Primary system
2	Secondary system

This type of mixing circuit is the most common one in all new installations.

The injection circuit operates with a variable flow on the primary side (1) and a constant flow on the secondary side (2).

Cold water is injected through a two-way valve into the secondary system (2) by opening the valve. On the secondary side (2), Warm water from the return pipe is mixed in through a bypass. The more water injected from the primary side (1), the less water is flowing through the bypass, resulting in a constant flow with a variable temperature at the load.

Because the bypass acts as a hydraulic short circuit, the pump in the secondary system (2) is not able to pump the water into the primary circuit. Therefore, this type of circuit is always pressurised in the primary system (1).

### Injection circuit with a three-way valve -heating system

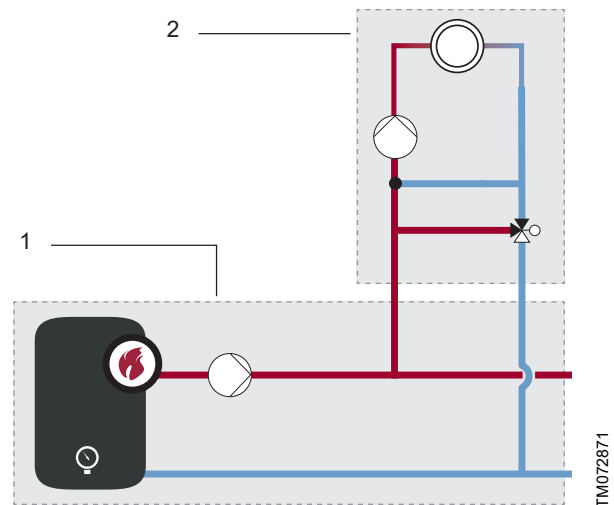

TM072871

Pos.	Description
1	Primary system
2	Secondary system

This type of circuit is advantageous when a fast response time is required and is often found in systems with long distances between heat generation and load. Because the flow and temperature in the primary system (1) are constant, the temperature in the secondary system (2) will increase instantly when water from the primary circuit is injected. The circuit is rarely used, though, as part of the primary flow is recirculated, and it is not applicable for district heating and condensing boiler because of the potential high temperatures in the system.

### Injection circuit with a three-way valve - cooling system

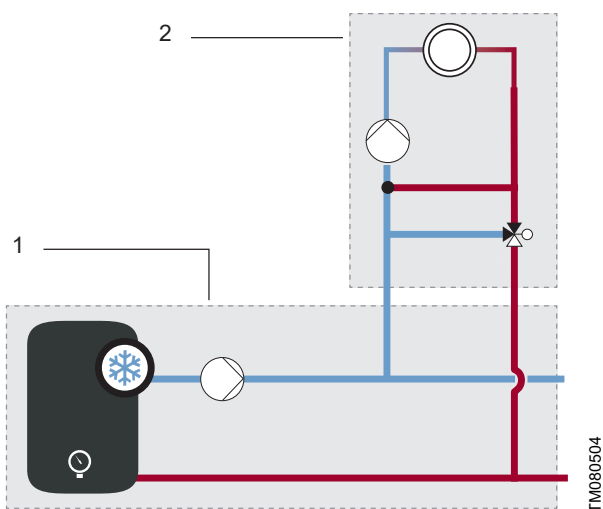

Pos.	Description
1	Primary system
2	Secondary system

This type of circuit is advantageous when a fast response time is required. Because the flow and temperature in the primary system (1) are constant, the temperature in the secondary system (2) will decrease instantly when water from the primary circuit is injected.

### Mixing circuit with a three-way valve - heating system

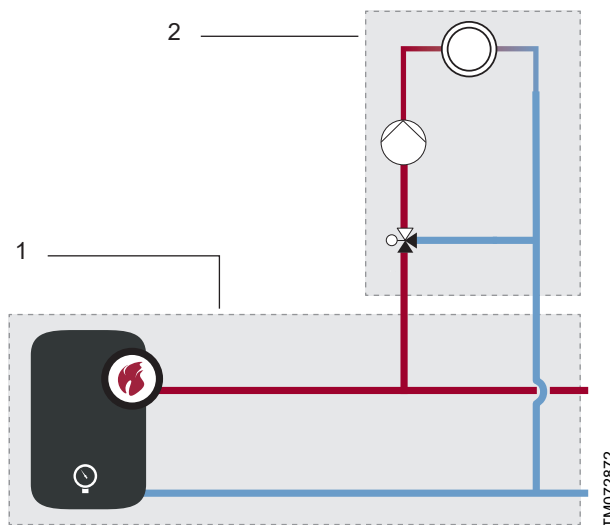

Pos.	Description
1	Primary system
2	Secondary system

The mixing circuit with a three-way valve is typically used in systems where the heat source allows a variable flow through it. Under these conditions, it is not necessary to have a primary pump. For this reason, this mixing circuit is not valid in applications where the boiler is far away from the valve.

The mixing circuit operates with a variable flow on the primary side (1) and a constant flow on the secondary side (2).

In this circuit, hot water is led through a three-way valve into the secondary system (2). Part of the secondary flow is recirculated through the valve. The two flows are mixed together at the mixing point inside the valve.

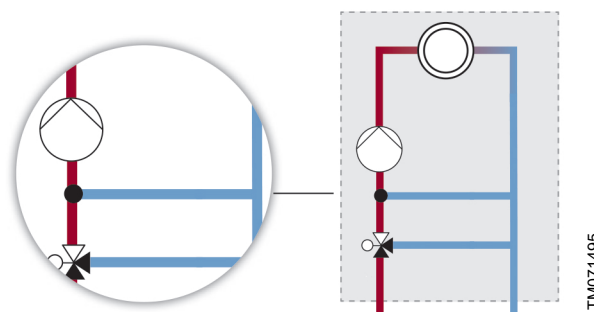

Fixed bypass in a mixing circuit with a three-way valve

When the primary flow temperature is significantly higher than the maximum secondary flow temperature, we recommend that you use the three-way mixing circuit with a fixed bypass. This is because the bypass ensures injection of return water even in the rare event of power failure or a stuck valve.

### Mixing circuit with a three-way valve -cooling system

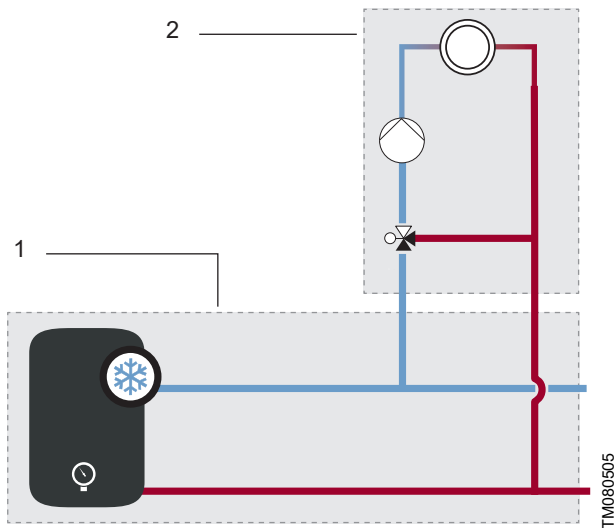

Pos.	Description
1	Primary system
2	Secondary system

The mixing circuit with a three-way valve is typically used in systems where the cooling source allows a variable flow through it. Under these conditions, it is not necessary to have a primary pump. For this reason, this mixing circuit is not valid in applications where the cooling unit is far away from the valve.

The mixing circuit operates with a variable flow on the primary side (1) and a constant flow on the secondary side (2).

In this circuit, cold water is led through a three-way valve into the secondary system (2). Part of the secondary flow is recirculated through the valve. The two flows are mixed together at the mixing point inside the valve.

### Combined heating and cooling system (mixing circuit, injection circuit, two-way valve and three-way valve)

The combined system (heating & cooling) uses both:

- injection circuit with two-way & three-way valve.
- mixing circuit with three-way valve

Combined systems are systems where the primary system can supply both hot and cold water. MIXIT can control the flow temperature for both heating and cooling in the secondary system. Changing the temperature controller between heating and cooling is done using external input or via fieldbus.

## MIXIT in a radiator heating system

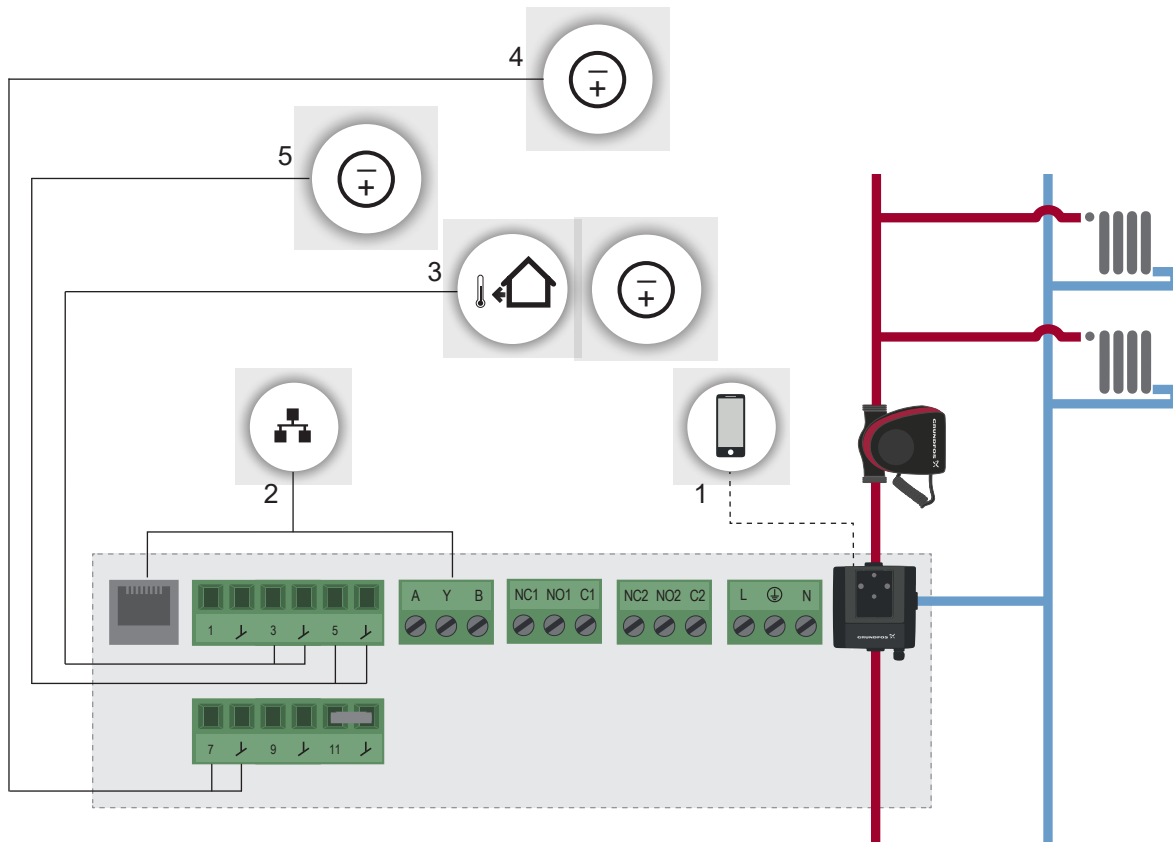

TM072873

Example of external connections in a radiator heating system

Pos.	Description
1	Bluetooth connection to smartphone via Grundfos GO Remote
2	Integration into BMS system
3	Outdoor temperature sensor (Pt1000) or External setpoint
4	Supply source set point
5	Daisy chain for supply source setpoint

In radiator heating systems, MIXIT will control the flow temperature supplied to the radiators. It can be used in both one- and two-pipe radiator installations. We recommend that you use thermostats on the individual radiators to set the desired room temperatures.

In the installation example above, MIXIT is configured with an outdoor temperature sensor, which is perfect for utilizing the following features:

- weather curve
- warm-weather shutdown.

### Data

MIXIT receives data on the mixed flow temperature from the pump's temperature sensor, while MIXIT itself measures:

- flow and temperature of the A port
- temperature of the B port.

These data can be used for the following features:

- temperature control
- pressure independence
- return temperature limit
- thermal power limit
- energy monitoring.

### Related information

- [6. Functions overview](#)
- [Terminal connections overview](#)

## Radiator heating, terminal connections

In a radiator heating system, the terminals can be used for the following:

Ethernet	RJ45		Communication to Grundfos BuildingConnect, Modbus TCP and BACnet IP.
I/O	1	+24 Volt	24 VDC supply for an active sensor.
	↓	GND	
	3	CI01	Outdoor temperature sensor (Pt1000 or 0-10 V).
	↓	GND	External setpoint input or position control (0-10 V, 0-20 mA or 4-20 mA).
	5	CI02	Daisy chain. Use daisy chain to connect two or more MIXIT units to support supply source setpoint.
	↓	GND	
I/O	7	CI03	Supply source setpoint voltage. Enables MIXIT to control the supply source output temperature and reduce pipe heat loss.
	↓	GND	
	9	DI4	External setpoint reduce. When the digital input is activated, MIXIT reduces the setpoint by 5 °C.
	↓	GND	
	11	DI5	External start/stop of both MIXIT and pump. When external stop is activated, MIXIT closes the valve and the pump stops.
	↓	GND	
RS-485	A	BACnet MS/TP Modbus RTU	Signal input and output from the BMS system. Via one of the listed protocol options.
	Y		
	B		
Relay 1	NC1		Fault signal. The NC/NO output signal will be active in case of fault.
	NO1		
	C1		
Relay 2	NC2		Run signal. The NC/NO output signal is active when MIXIT operates in temperature control.
	NO2		
	C2		
AC supply	L	Mains supply	Power supply connection, 230 V ± 10 %.
	Earth		
	N		

### Configuring the I/O terminals according to the terminal connections table

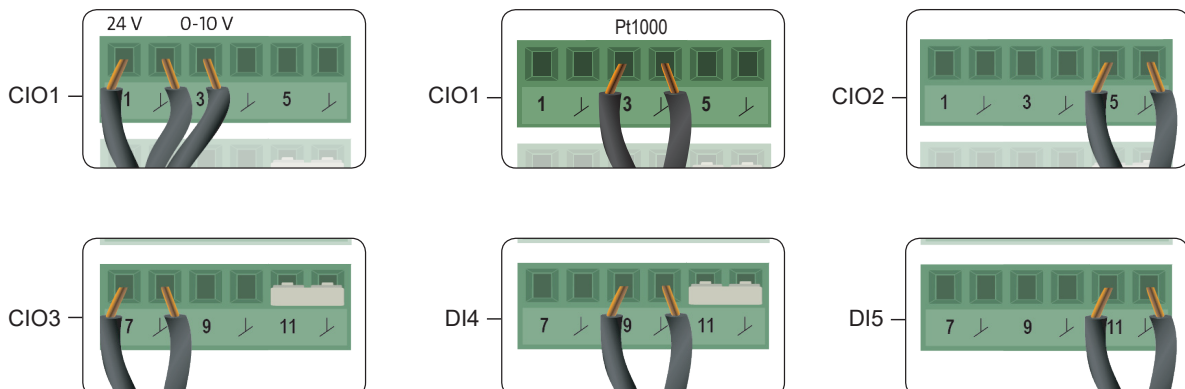

TM074677

## MIXIT in an underfloor heating system

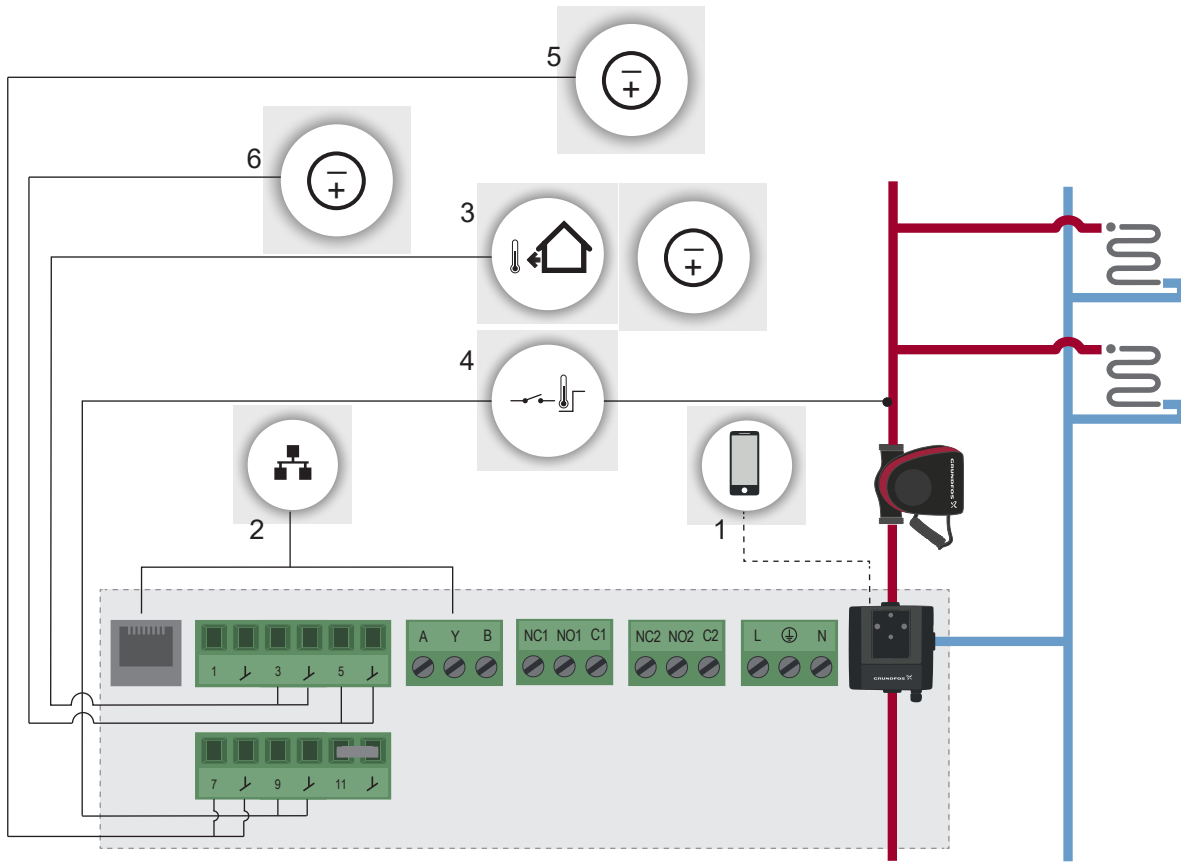

TM072874

Example of external connections in an underfloor heating system

Pos.	Description
1	Bluetooth connection to smartphone via Grundfos GO Remote
2	Integration into BMS system
3	Outdoor temperature sensor (Pt1000) or External setpoint
4	Temperature protection switch (extra thermal protection)
5	Supply source setpoint
6	Daisy chain for supply source setpoint

In underfloor heating systems, MIXIT will control the flow temperature supplied to the connected underfloor heating zones.

In the installation example above, MIXIT is configured with the following:

- An outdoor temperature sensor, perfect for utilizing the following features:
  - weather curve
  - warm-weather shutdown.
- A bimetallic temperature protection switch providing thermal protection. Once a defined maximum temperature is reached, the temperature switch activates the input terminal of the MIXIT unit causing the valve to close. The switch acts as extra protection as MIXIT already controls the mixed

flow temperature and has a built-in floor overheat protection function. See the section on underfloor overheat protection.

### Data

MIXIT receives data on the mixed flow temperature from the pump's temperature sensor, while MIXIT itself measures:

- flow and temperature of the A port
- temperature of the B port.

These data can be used for the following features:

- temperature control
- pressure independence
- return temperature limit
- thermal power limit
- energy monitoring.

### Related information

- [6. Functions overview](#)
- [Underfloor overheat protection](#)
- [Terminal connections overview](#)

## Underfloor heating, terminal connections

In an underfloor heating system, the terminals can be used for the following:

Ethernet	RJ45		Communication to Grundfos BuildingConnect, Modbus TCP and BACnet IP.
I/O	1	+24 Volt	24 VDC supply for an active sensor.
	↓	GND	
	3	CI01	Outdoor temperature sensor (Pt1000 or 0-10 V). External setpoint input or position control (0-10 V, 0-20 mA or 4-20 mA).
	↓	GND	
	5	CI02	Daisy chain. Use daisy chain to connect two or more MIXIT units to support supply source setpoint.
	↓	GND	
I/O	7	CI03	Supply source setpoint voltage. Enables MIXIT to control the supply source output temperature and reduce pipe heat loss.
	↓	GND	
	9	DI4	External overheat indicator. When activated, MIXIT closes the valve and the pump stops.
	↓	GND	
	11	DI5	External start/stop of both MIXIT and pump. external stop is activated, MIXIT closes the valve and the pump stops.
	↓	GND	
RS-485	A	BACnet MS/TP Modbus RTU	Signal input and output from the BMS system.
	Y		
	B		
Relay 1	NC1		Fault signal. The NC/NO output signal will be active in case of fault.
	NO1		
	C1		
Relay 2	NC2		Run signal. The NC/NO output signal is active when MIXIT operates in temperature control.
	NO2		
	C2		
AC supply	L	Mains supply	Power supply connection, 230 V ± 10 %.
	Earth		
	N		

### Configuring the I/O terminals according to the terminal connections table

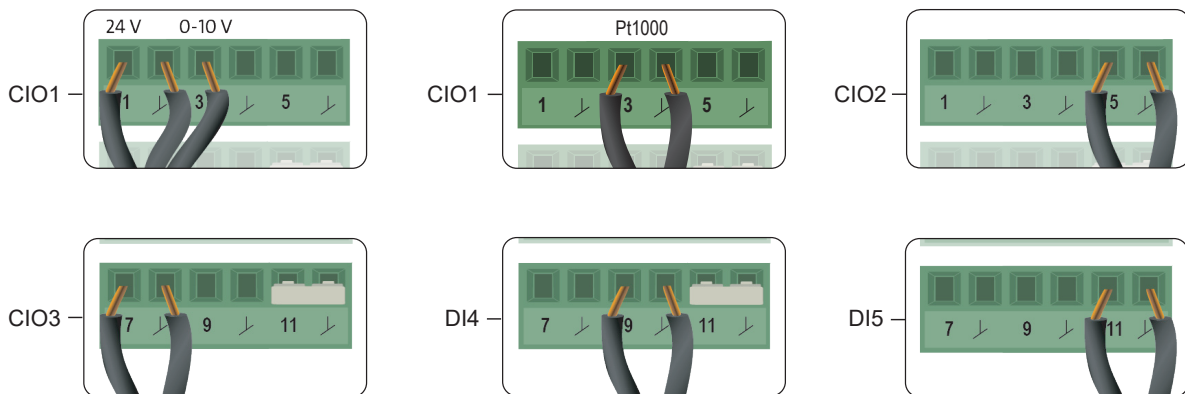

TM074676

## MIXIT in an air handling unit system

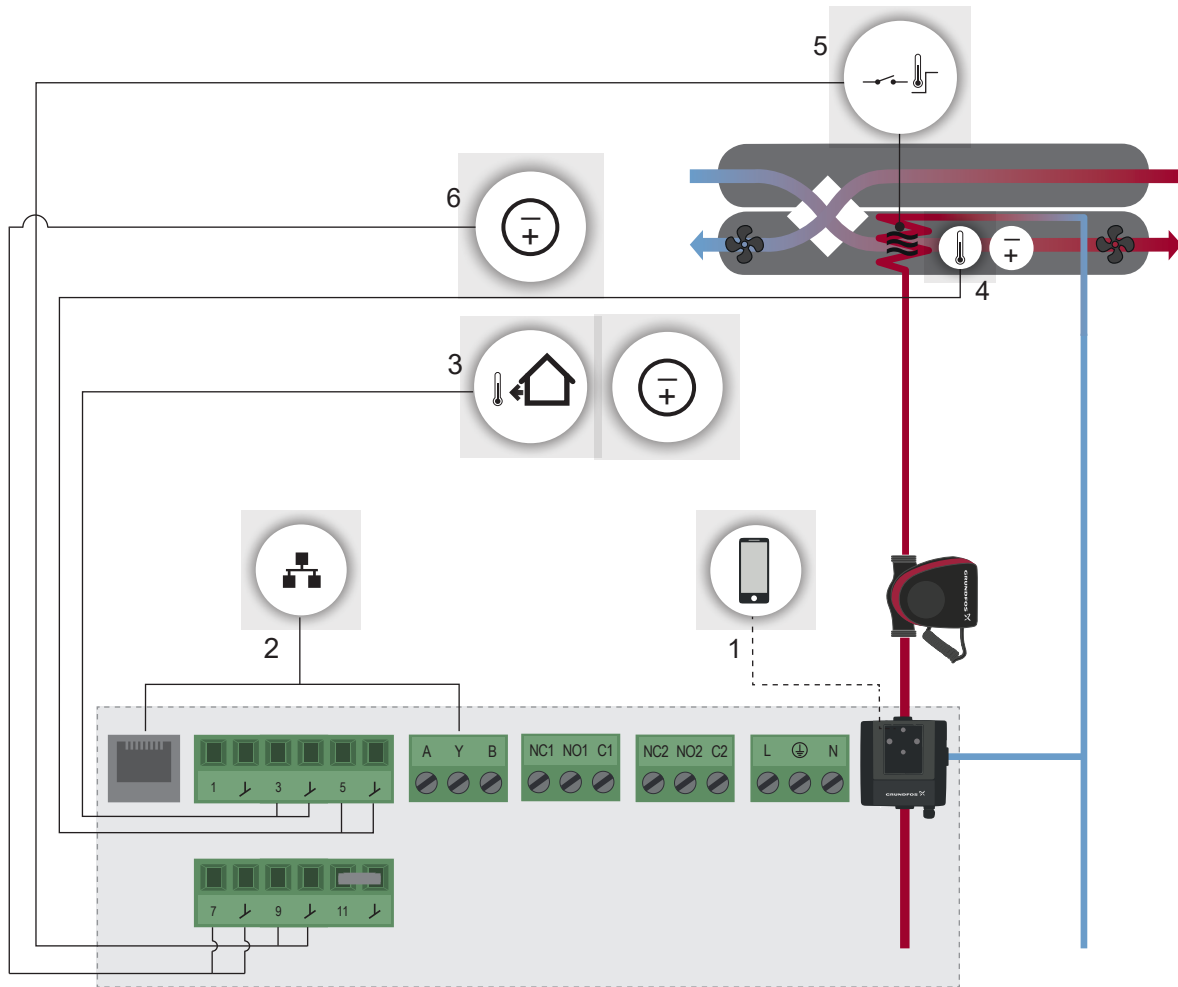

TM072875

Example of external connections in an air handling unit

Pos.	Description
1	Bluetooth connection
2	System integration
3	Outdoor temperature sensor (Pt1000) or External setpoint
4	Air temperature sensor or Daisy chain for supply source setpoint
5	Antifreeze sensor (extra protection against freezing)
6	Supply source setpoint

In air handling unit systems, MIXIT will control the flow temperature supplied to the air coil placed within the air handling unit. The flow temperature will be determined by the setpoint of the air temperature measured in the outlet temperature of the air handling unit.

In the installation example above, MIXIT is configured with:

- An outdoor temperature sensor, perfect for utilising the following features:
  - weather curve
  - warm-weather shutdown.

- An antifreeze sensor for the system to avoid ice building up in the air handling unit and frost damage. The sensor acts as extra protection, as MIXIT offers several antifreeze functions to protect the system:
  - A purge function which preheats the coil before activating the enable signal in relay 2. The signal can be used to open the dampers and let in air. Furthermore, an internal frost protection can be set. Both functions are available when setting up MIXIT in Grundfos GO Remote. See the section on heating coil preheat and frost protection.
  - MIXIT has a digital input, which can be connected to an external bimetallic temperature switch.
- An air temperature sensor placed in the outlet of the unit to ensure correct air temperature.

### Data

MIXIT receives air temperature data from the temperature sensor mounted in the outlet of the air handling unit, while MIXIT itself measures:

- flow and temperature of the A port
- temperature of the B port.

These data can be used for the following features:

- temperature control
- pressure independence
- return temperature limit
- thermal power limit
- energy monitoring.

**Related information**

[6. Functions overview](#)

[Heating coil preheat and frost protection](#)

[Terminal connections overview](#)

### Air handling unit, terminal connections

In an air handling unit system, the terminals can be used for the following:

Ethernet	RJ45		Communication to Grundfos BuildingConnect, Modbus TCP and BACnet IP.
I/O	1	+24 Volt	24 VDC supply for an active sensor.
	↓	GND	
	3	CI01	Outdoor temperature sensor (Pt1000 or 0-10 V).
	↓	GND	External setpoint input or position control (0-10 V, 0-20 mA or 4-20 mA).
	5	CI02	Air temperature sensor or daisy chain. Use daisy chain to connect two or more MIXIT units to support supply source setpoint.
	↓	GND	
I/O	7	CI03	Supply source setpoint voltage. Enables MIXIT to control the supply source output temperature and reduce pipe heat loss.
	↓	GND	
	9	DI4	External frost indicator. When activated, MIXIT will react by fully opening the valve so that the pump can circulate hot water in the system.
	↓	GND	
I/O	11	DI5	External start/stop of both MIXIT and pump. When external stop is activated, MIXIT closes the valve and the pump stops.
	↓	GND	
	↓	GND	
RS-485	A	BACnet MS/TP Modbus RTU	Signal input and output from the BMS system.
	Y		
	B		
Relay 1	NC1		Fault signal. The NC/NO output signal will be active in case of fault.
	NO1		
	C1		
Relay 2	NC2		Run signal. The NC/NO output signal is active when MIXIT operates in temperature control. The signal is inactive in frost protection mode and preheat mode.
	NO2		
	C2		
AC supply	L	Mains supply	Power supply connection, 230 V ± 10 %.
	Earth		
	N		

#### Configuring the I/O terminals according to the terminal connections table

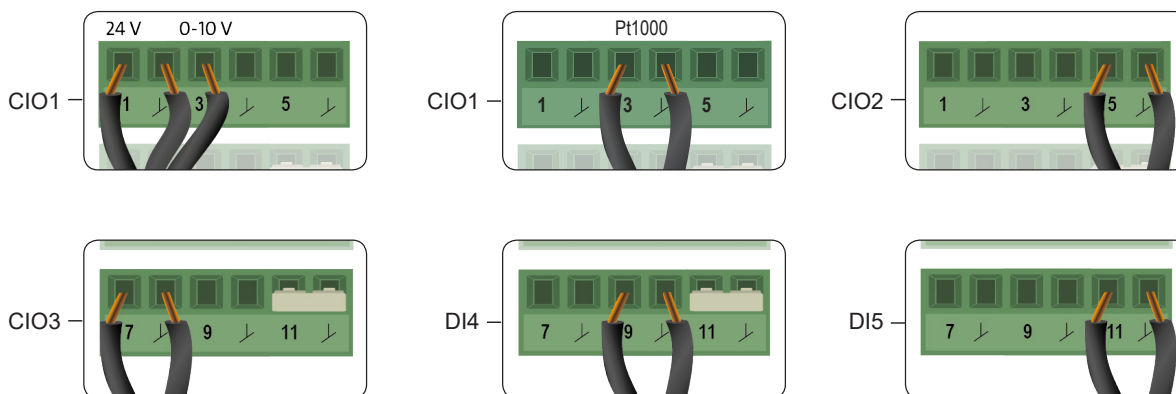

TM074684

## MIXIT in a cooling system

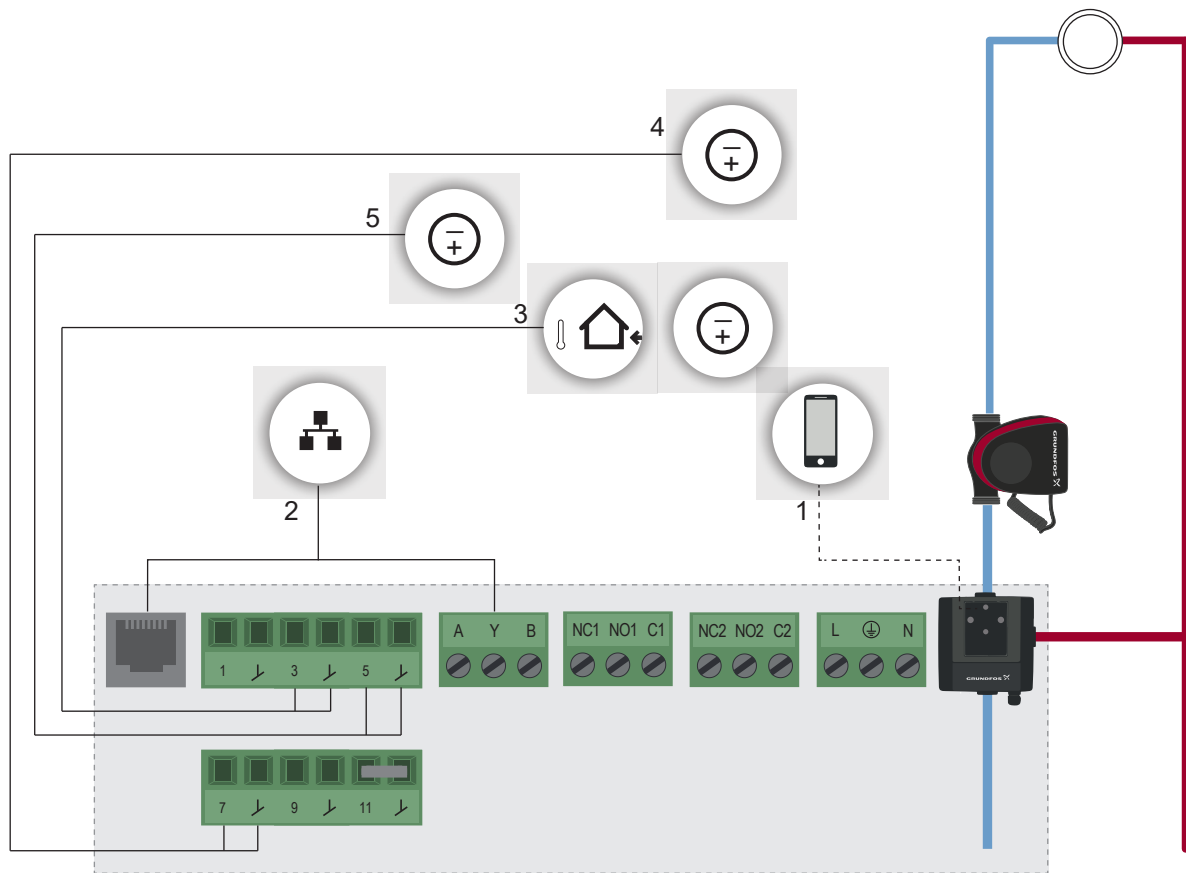

TM080501

### Example of cooling system

Pos.	Description
1	Bluetooth connection to smartphone via Grundfos GO Remote
2	Integration into BMS system
3	Outdoor temperature sensor (Pt1000 or 0-10 V) or external setpoint
4	Supply source setpoint
5	Daisy chain for supply source setpoint

In cooling systems, MIXIT will control the flow temperature supplied to the cooling systems.

#### Data

MIXIT receives data on the mixed flow temperature from the pump's temperature sensor, while MIXIT itself measures:

- flow and temperature of the A port
- temperature of the B port.

These data can be used for the following features:

- temperature control
- pressure independence
- return temperature limit
- thermal power limit
- energy monitoring.

#### Related information

[6. Functions overview](#)

### Cooling, terminal connections

In the cooling system, the terminals can be used for the following:

Ethernet	RJ45		Communication to Grundfos BuildingConnect, Modbus TCP and BACnet IP.
I/O	1	+24 Volt	24 VDC supply for an active sensor.
	↘	GND	
	3	CI01	Outdoor temperature sensor (Pt1000 or 0-10 V). External setpoint input or position control (0-10 V, 0-20 mA or 4-20 mA).
	↘	GND	
	5	CI02	Daisy chain. Use daisy chain to connect two or more MIXIT units to support supply source setpoint.
	↘	GND	
I/O	7	CI03	Supply source setpoint voltage. Enables MIXIT to control the supply source output temperature and reduce pipe heat loss.
	↘	GND	
	9	DI4	External start/stop of both MIXIT and pump. When external stop is activated, MIXIT closes the valve and the pump stops.
	↘	GND	
	11	DI5	
	↘	GND	
RS-485	A	BACnet MS/TP Modbus RTU	Signal input and output from the BMS system.
	Y		
	B		
Relay 1	NC1		Fault signal. The NC/NO output signal will be active in case of fault.
	NO1		
	C1		
Relay 2	NC2		Run signal. The NC/NO output signal is active when MIXIT operates in temperature control. The signal is inactive in frost protection mode and preheat mode.
	NO2		
	C2		
AC supply	L	Mains supply	Power supply connection, 230 V ± 10 %.
	Earth		
	N		

#### Configuring the I/O terminals according to the terminal connections table

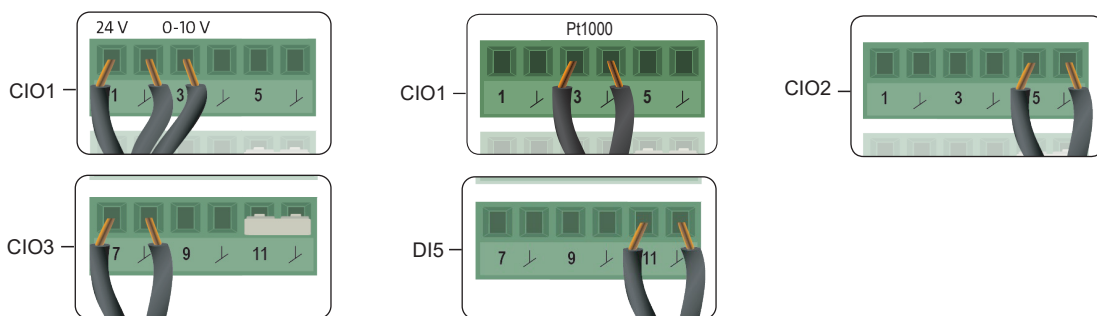

TM081863

## MIXIT in a combined system (heating and cooling)

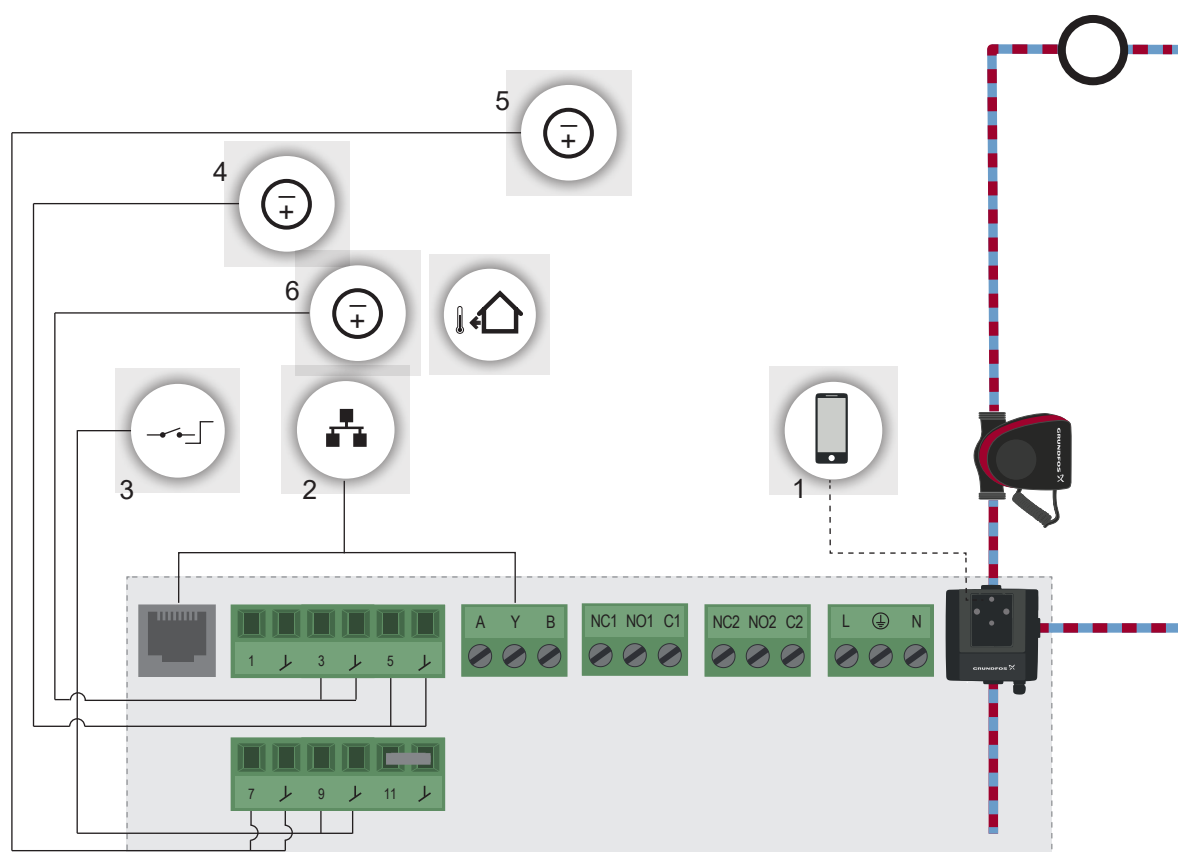

TM080502

Example of MIXIT in a combined heating and cooling system

Pos.	Description
1	Bluetooth connection to smartphone via Grundfos GO Remote
2	Integration into BMS system
3	DI4 (To switch between heating and cooling mode)
4	Daisy chain for supply source setpoint
5	Supply source setpoint
6	Outdoor temperature sensor (Pt1000 or 0-10 V) or External setpoint

- thermal power limit
- energy monitoring.

### Related information

[6. Functions overview](#)

In combined systems, MIXIT will control the flow temperature supplied to the heating/cooling systems based on which system is selected for use.

In the installation example above, MIXIT is configured with an external switch that changes between heating and cooling mode, which is perfect for utilizing the following features:

### Data

MIXIT receives data on the mixed flow temperature from the pump's temperature sensor, while MIXIT itself measures:

- flow and temperature of the A port
- temperature of the B port.

These data can be used for the following features:

- temperature control
- pressure independence
- return temperature limit

### Combined heating and cooling, terminal connections

In the combined heating and cooling, the terminals can be used for the following:

Ethernet	RJ45		Communication to Grundfos BuildingConnect, Modbus TCP and BACnet IP.
I/O	1	+24 Volt	24 VDC supply for an active sensor.
	↓	GND	
	3	CI01	Outdoor temperature sensor (Pt1000 or 0-10 V).
	↓	GND	External setpoint input or position control (0-10 V, 0-20 mA or 4-20 mA).
	5	CI02	Daisy chain. Use daisy chain to connect two or more MIXIT units to support supply source setpoint.
	↓	GND	
I/O	7	CI03	Supply source setpoint voltage. Enables MIXIT to control the supply source output temperature and reduce pipe heat loss.
	↓	GND	
	9	DI4	Switches between heating and cooling. When the digital input is active, MIXIT will be in the cooling mode. The default setting is in heating mode.
	↓	GND	
	11	DI5	External start/stop of both MIXIT and pump. When external stop is activated, MIXIT closes the valve and the pump stops.
	↓	GND	
RS-485	A	BACnet MS/TP Modbus RTU	Signal input and output from the BMS system.
	Y		
	B		
Relay 1	NC1		Fault signal. The NC/NO output signal will be active in case of fault.
	NO1		
	C1		
Relay 2	NC2		Run signal. The NC/NO output signal is active when MIXIT operates in temperature control. The signal is inactive in frost protection mode and preheat mode.
	NO2		
	C2		
AC supply	L	Mains supply	Power supply connection, 230 V ± 10 %.
	Earth		
	N		

#### Configuring the I/O terminals according to the terminal connections table

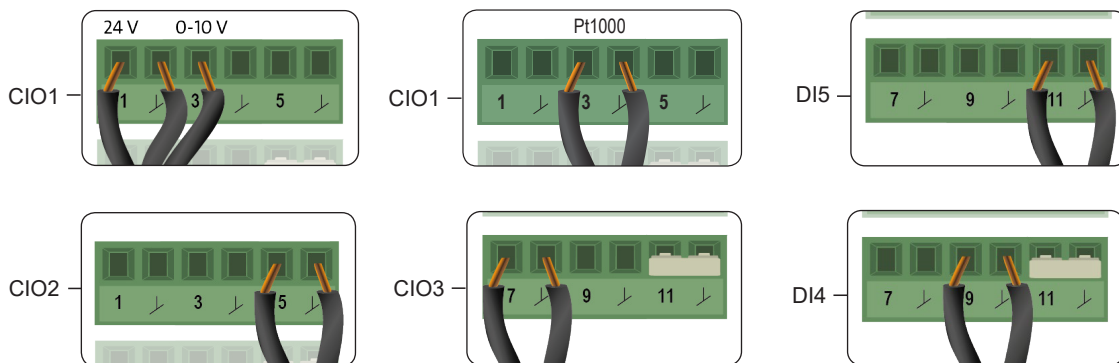

TM081864



During commissioning, it is possible to change over between heating and cooling control by activating DI4.

## 5. Components

### Threaded Version

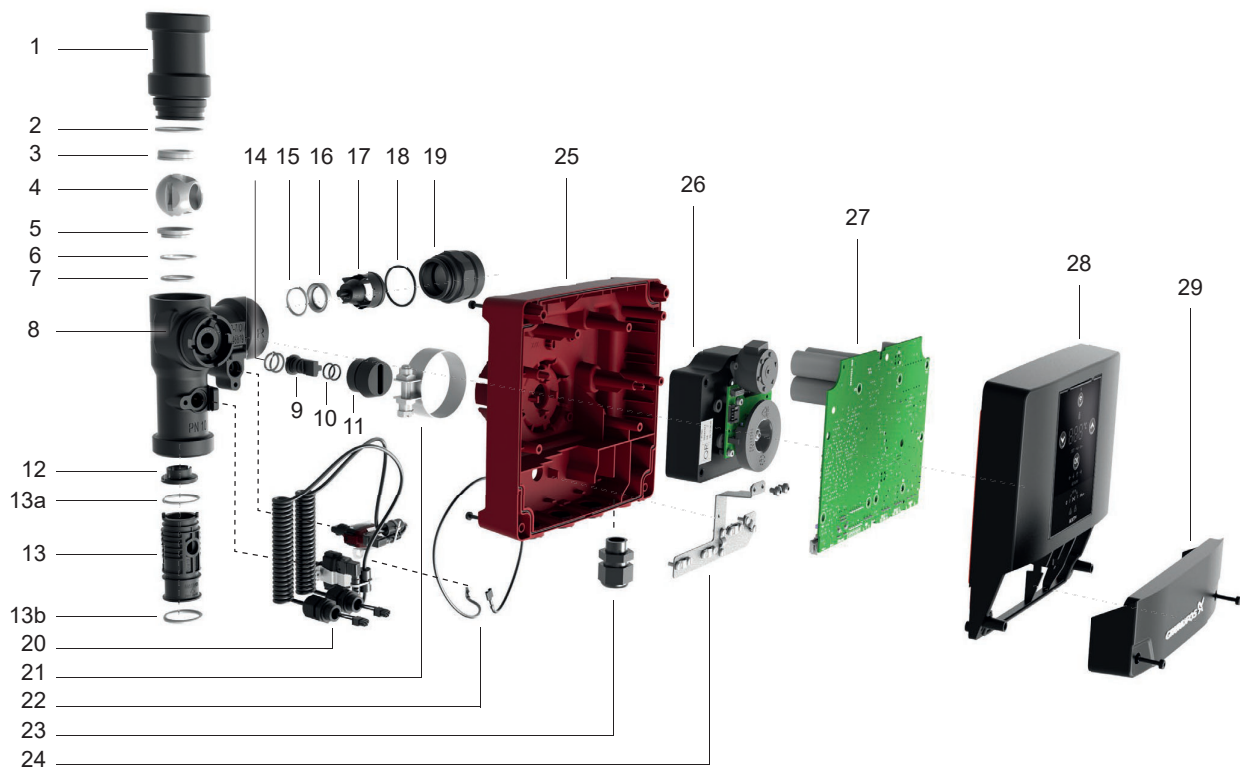

TM071483

Pos.	Description	Material
1	Retainer AB	Cast iron GJS500-7 and CED
2	O-ring	EPDM (EP70)
3	Seat AB	Carbon reinforced PTFE
4	Ball valve	Brass CW641N, Ni and Cr
5	Seat A	Carbon reinforced PTFE
6	Washer	Stainless steel EN1.4301
7	O-ring	EPDM (EP70)
8	Valve body	Cast iron GJS500-7 and CED
9	Stem	Stainless steel
10	O-rings	EPDM (EP70)
11	Coupling	Brass CW614N
12	Flow restriction disc	PPS 40-GF
13	Flow insert	PPS 40-GF
13a	O-ring	EPDM (EP70)
13b	O-ring	EPDM (EP70)
14	Bearings for stem	PTFE

Pos.	Description	Material
15	O-ring	EPDM (EP70)
16	Seat B	Carbon reinforced PTFE
17	Non-return valve	EPDM, Stainless steel, PPO
18	O-ring	EPDM (EP70)
19	Retainer B	Cast iron GJS500-7 and CED
20	Sensors	Wetted materials: Corrosion-resistant coating, EPDM, PPS
21	Clamp	Stainless steel EN1.4301
22	Grounding cable	
23	Cable gland	PA
24	Earth plate	Stainless steel
25	Control box housing	Makrolon 9415 PC 10%GF FR
26	Motor gear unit	
27	MIXIT main board	
28	MIXIT cover	Makrolon 9415 PC 10%GF FR
29	Terminal cover	Makrolon 9415 PC 10%GF FR

Flanged Version

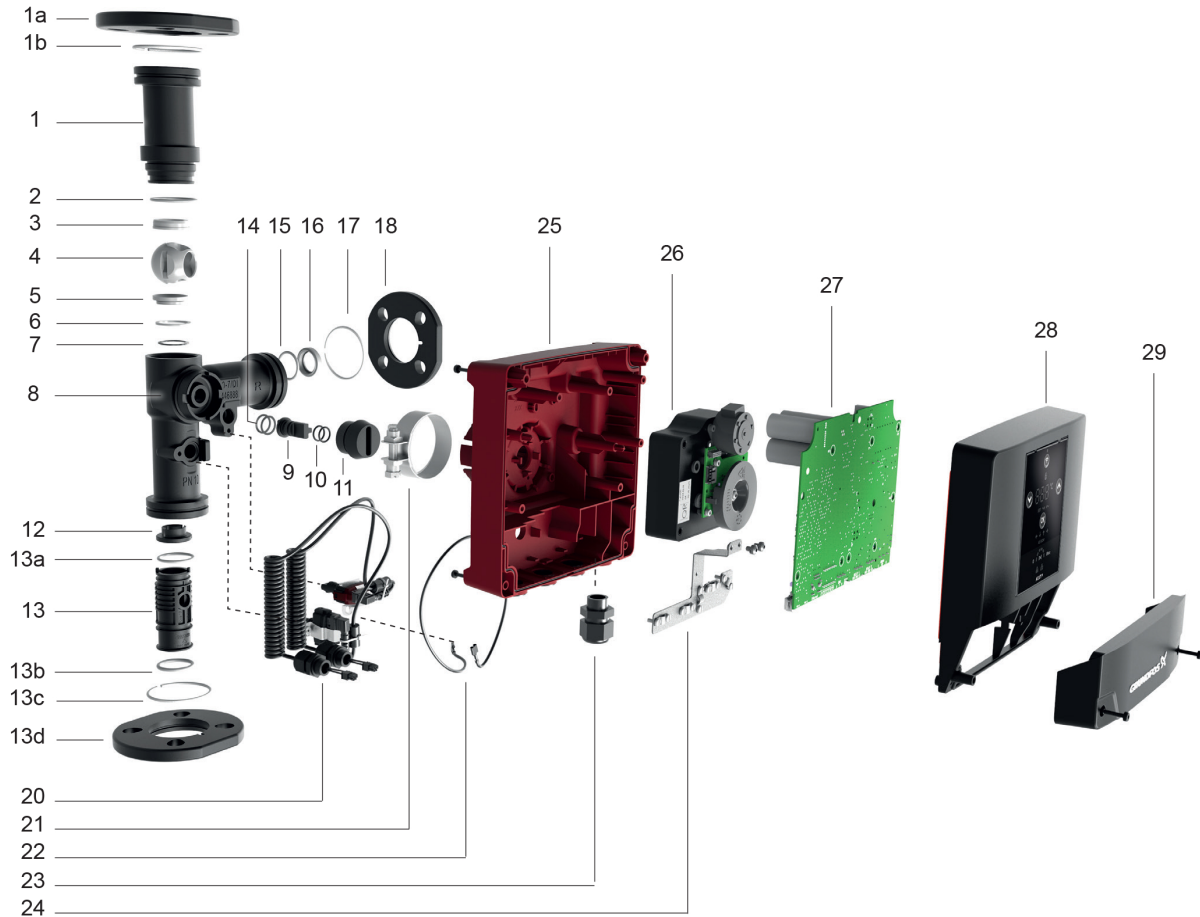

TM080478

Pos.	Description	Material
1	Retainer AB	Cast iron GJS500-7 and CED
1a	Flange	Stainless steel EN 1.4308 and CED
1b	Lock ring d74,6/d5	EN 1.4310
2	O-ring	EPDM (EP70)
3	Seat AB	Carbon reinforced PTFE
4	Ball valve	Brass CW641N, Ni and Cr
5	Seat A	Carbon reinforced PTFE
6	Washer	Stainless steel EN1.4301
7	O-ring	EPDM (EP70)
8	Valve body	Cast iron GJS500-7 and CED
9	Stem	Stainless steel
10	O-rings	EPDM (EP70)
11	Coupling	Brass CW614N
12	Flow restriction disc	PPS 40-GF
13	Flow insert	PPS 40-GF
13a	O-ring	EPDM (EP70)
13b	O-ring	EPDM (EP70)
13c	Lock ring d74,6/d5	EN 1.4310
13d	Flange	Stainless steel EN 1.4308 and CED
14	Bearings for stem	PTFE
15	O-ring	EPDM (EP70)
16	Seat B	Carbon reinforced PTFE
17	Lock ring d74,6/d5	EN 1.4310
18	Flange	Stainless steel EN 1.4308 and CED
20	Sensors	Wetted materials: Corrosion-resistant coating, EPDM, PPS

Pos.	Description	Material
21	Clamp	Stainless steel EN1.4301
22	Grounding cable	
23	Cable gland	PA
24	Earth plate	Stainless steel
25	Control box housing	Makrolon 9415 PC 10%GF FR
26	Motor gear unit	
27	MIXIT main board	
28	MIXIT cover	Makrolon 9415 PC 10%GF FR
29	Terminal cover	Makrolon 9415 PC 10%GF FR

## Ball valve

MIXIT leads water through port A and lets return water in through port B. The mixed water is then let out through the AB port.



## Two-way valve with a shunt

By turning the ball valve in a clockwise direction (I-II-III), port A goes from closed to fully open position and vice-versa in a counterclockwise direction (III-II-I). Port B is always fully open and works as a shunt.

## Three-way valve

By adjusting the angle of the ball valve in a counterclockwise direction (I-II-III), port A goes from closed to a fully open position, while port B goes from fully open to closed. The opposite happens when the ball valve is adjusted in a clockwise direction (III-II-I).

## Two-way and three-way valves

Due to the unique design of the ball valve, MIXIT can be configured both as a two-way valve and a three-way valve. MIXIT does this by simply changing the opening direction of the ball valve.

## Two- and three way operation

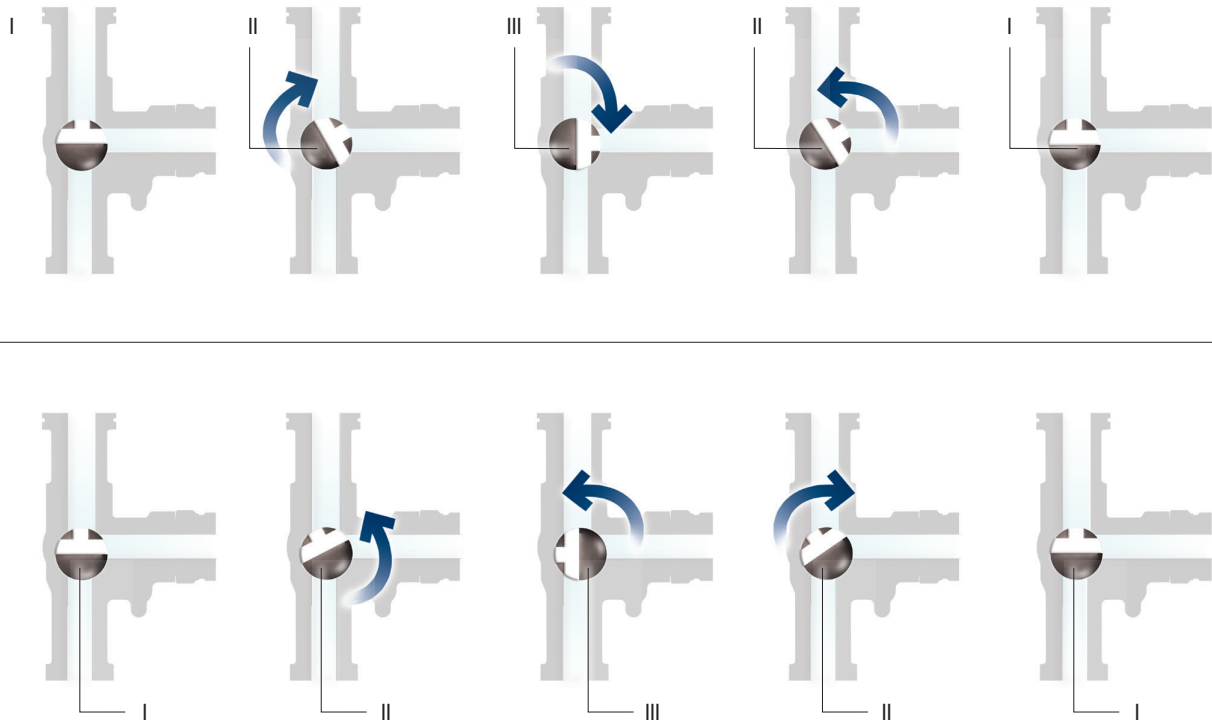

Top: two-way operation, bottom: three-way operation

TM071482

## Non-return valve

Some systems require a non-return valve, while other systems might not need it. The non-return valve ensures that the liquid flows through the pipe in the correct direction where pressure conditions may otherwise cause a reversed flow.

- Threaded versions of MIXIT are factory fitted with a non-return valve. If the non-return valve is not required, it can easily be removed to eliminate any unwanted resistance.
- Flanged versions of MIXIT do not include the non-return valve. If required, install a non-return valve externally at the B-port of the MIXIT unit.

## Seats

The PTFE seats in MIXIT offer low friction and a high level of tightness. The EPDM O-rings located between the valve housing and seats in ports A and B create compression making the valve less sensitive to wear and tolerances.

## Sensors

The valve has integrated flow and temperature sensors. The Integrated Temperature sensor Standard (ITS2) measures the temperature at the B-port. The Vortex Flow sensor Standard (VFS) measures the flow at the A-port, which is used for the pressure independent functionality. Additionally, it measures the temperature at the A-port.

Due to these sensors, the high mechanical resolution of the control valve and the construction of the ball valve, it is possible for MIXIT to operate effectively with a lower pressure difference than traditional mechanical solutions. When paired with a MAGNA3/TPE3 pump, MIXIT is able to use all the pump parameters.

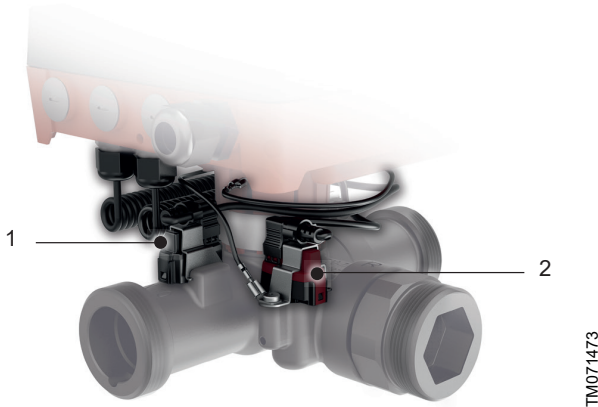

Pos.	Description
1	Vortex Flow sensor Standard (VFS)
2	Integrated Temperature sensor Standard (ITS2)

### Related information

[Integrated Temperature sensor Standard \(ITS2\)](#)  
[Vortex Flow sensor Standard \(VFS\)](#)

## Vortex Flow sensor Standard (VFS)

The Vortex Flow sensor Standard (VFS) is a combined flow and temperature sensor (two-in-one) from Grundfos Direct Sensors™. The sensor is based on the principle of vortex shedding behind a bluff body. The VFS sensor is fully compatible with wet, aggressive liquids. The sensor is based on a Micro Electro-Mechanical System (MEMS) sensing technology in combination with the corrosion-resistant Silicoat® coating technology on the sensor chip.

### Related information

[Sensors](#)

## Integrated Temperature sensor Standard (ITS2)

The Integrated Temperature sensor Standard (ITS2) is a temperature sensor from Grundfos Direct Sensors™. The ITS2 sensor is fully compatible with wet, aggressive liquids. The sensor is based on a Micro Electro-Mechanical System (MEMS) sensing technology in combination with the corrosion resistant Silicoat® coating technology on the sensor chip.

### Related information

[Sensors](#)

## 6. Functions overview

All required functions and controls of a mixing loop are built into MIXIT. Not only does this mean simple implementation and installation, but also an efficient, reliable and smooth operation.

	MIXIT valve unit	MIXIT DYNAMIC valve unit	DYNAMIC upgrade	CONNECT upgrade
Standard functions	Temperature controller	•	•	
	Underfloor overhear protection (for underfloor heating systems)	•	•	
	Heating coil preheat and frost protection (for air handling unit systems)	•	•	
	Frost protection (for cooling and combined applications)	•	•	
	External setpoint reduction of 5 °C. (for radiator heating systems)	•	•	
	Pump control modes: <ul style="list-style-type: none"> <li>• AUTOADAPT</li> <li>• Proportional pressure</li> <li>• Constant pressure</li> <li>• Constant flow</li> <li>• Constant curve/constant speed</li> </ul>	•	•	
	Position control	•	•	
	Weather curve	•	•	
	Supply source setpoint	•	•	
	Eco functions	Eco schedule <ul style="list-style-type: none"> <li>• Eco periods</li> <li>• Temperature setback or system turn off</li> <li>• Single events</li> </ul>	•	•
Warm weather shutdown		•	•	
Pressure independence			•	•
Energy monitoring			•	•
Balancing limiters <ul style="list-style-type: none"> <li>• Supply flow limit</li> <li>• Return temperature limit</li> <li>• Thermal power limit</li> <li>• Differential temperature limit</li> </ul>			•	•
Grundfos BuildingConnect Free Monitoring		•	•	•
Monitoring and control	Grundfos BuildingConnect Professional			•
	Fieldbus integration (BACnet and Modbus)			•



You can upgrade MIXIT to DYNAMIC or CONNECT at any time via Grundfos GO Remote. The DYNAMIC and CONNECT upgrades can be combined.

### Related information

[MIXIT in a radiator heating system](#)

[MIXIT in an underfloor heating system](#)

[MIXIT in an air handling unit system](#)

[MIXIT in a cooling system](#)

[MIXIT in a combined system \(heating and cooling\)](#)

## MIXIT variants and upgrades

The standard functions are always included. The DYNAMIC and CONNECT upgrades can be combined. You can upgrade MIXIT at any time via Grundfos GO Remote.

### **MIXIT, valve unit variant**

The functions in MIXIT are standard and are mainly suited for three-way installations in large buildings, such as schools, with no need for monitoring, pressure independence or balancing.

MIXIT gives access to Grundfos BuildingConnect Free Monitoring.

MIXIT can be upgraded with DYNAMIC and CONNECT at any time.

### **MIXIT DYNAMIC, valve unit variant**

MIXIT DYNAMIC includes balancing limiters functions, pressure independence as well as the Free Monitoring version of Grundfos BuildingConnect. This valve unit is recommended for pressurised applications, where pressure independence, energy monitoring and flow or energy balancing are required.

MIXIT DYNAMIC can be upgraded with CONNECT.

The energy monitoring functionality is automatically activated when MIXIT is upgraded with the DYNAMIC upgrade or if the MIXIT unit is a MIXIT DYNAMIC.

### **DYNAMIC upgrade**

The DYNAMIC upgrade offers balancing limiters functions and pressure independence. Also, it gives access to the Grundfos BuildingConnect Free Monitoring solution.

The DYNAMIC and CONNECT upgrades can be combined.

### **CONNECT upgrade**

CONNECT is suitable when MIXIT operates as a subsystem in large installations where a BMS system is already in place. The upgrade enables you to connect MIXIT to a building management system via fieldbus (BACnet or Modbus) and gives access to Grundfos BuildingConnect Professional.

The DYNAMIC and CONNECT upgrades can be combined.

## Temperature controller

From factory MIXIT is configured so that the temperature response of the system in most cases corresponds to the centre graph in the below figure. This is the ideal response. However, in some cases it may be necessary to make adjustments.

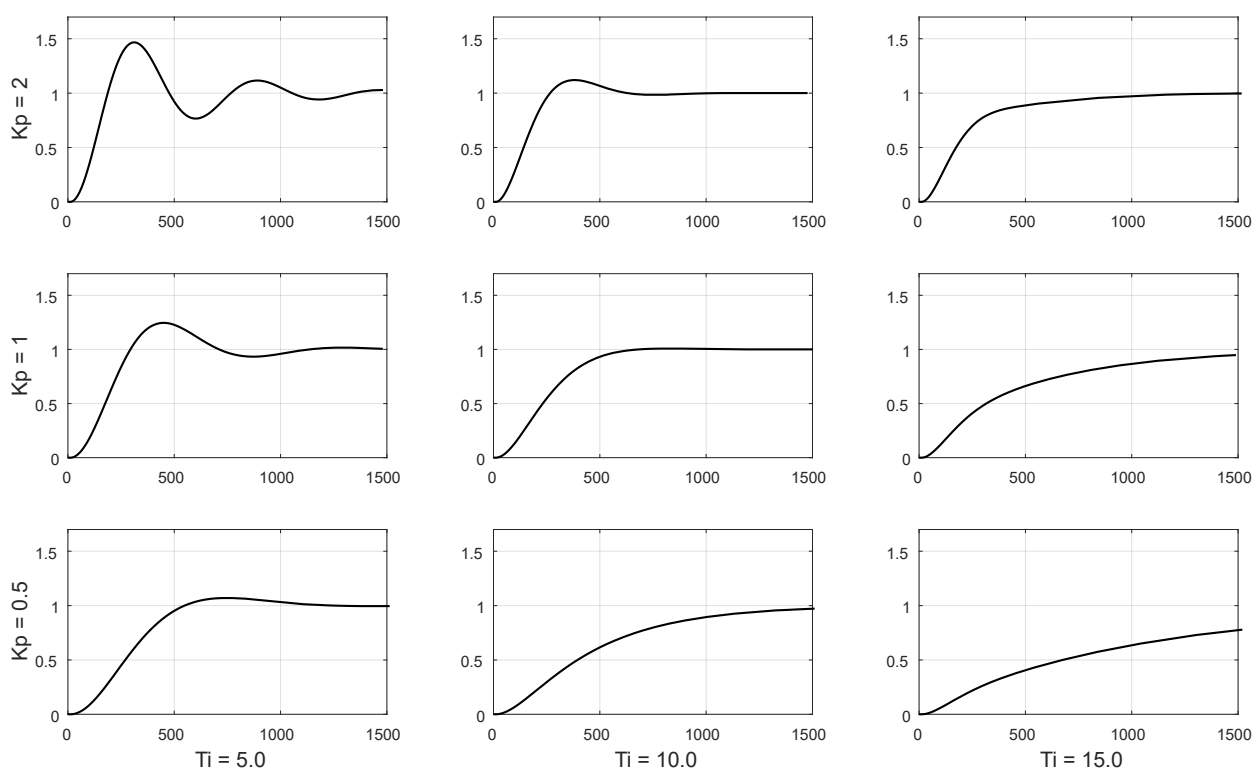

TM077581

The figure shows the typical responses to a step input for PI controlled systems such as MIXIT:

- By increasing the proportional gain ( $K_p$ ) of the controller, the response rises more rapidly. If the gain is too high, undamped oscillations occur. If the gain is even higher, the oscillation of the temperature will continue, causing instability.
- By decreasing the proportional gain ( $K_p$ ) of the controller, the response becomes slower.
- By increasing the integral time ( $T_i$ ), the response becomes slower and it takes longer to reach the setpoint.
- By decreasing the integral time ( $T_i$ ), the response becomes faster and it takes shorter time to reach the setpoint.

## Underfloor overheat protection

When choosing the application type **Underfloor heating**, you automatically activate the **Underfloor overheat protection** function.

In Grundfos GO Remote you define a maximum forward-flow temperature. The temperature will never exceed the given value, thus protecting the floor from overheating.

### Related information

[MIXIT in an underfloor heating system](#)

## Heating coil preheat and frost protection

When choosing the application type **Heating coil**, you automatically activate the **Coil preheat and frost protection** functions.

### Coil preheat

With MIXIT you can preheat the coil before allowing the fan to start.

By preheating the coil, you can ensure a higher level of comfort and minimize the risk of frost in the coil. To indicate when the coil is heated, you define a return temperature threshold in Grundfos GO Remote.

### Frost protection

You can protect the coil from freezing by defining limits for the return flow temperature and air temperature. If the temperature falls below one of these two temperature limits, MIXIT will react by fully opening the valve in order to circulate hot water in the system.

The return flow temperature is measured by the sensor in port B of MIXIT. To measure the air temperature, you need to either install a temperature sensor in the coil or have the temperature data sent via fieldbus.

### Related information

[MIXIT in an air handling unit system](#)

## Frost protection for cooling

When choosing the application type **Cooling**, you automatically activate the **Frost protection** function.

You can protect the coil from freezing by defining a return flow temperature limit in Grundfos GO Remote. If the temperature falls below this temperature limit, MIXIT will react by fully opening the valve in order to circulate water in the system.

The return flow temperature is measured by the sensor in port B of MIXIT.

## Frost protection for combined heating and cooling

When choosing the application type **Combined heating and cooling**, you automatically activate the **Frost protection** function.

Depending on the season, you can protect your combined heating and cooling system from freezing. In Grundfos GO Remote you can define individual return flow temperature limits for your heating system and your cooling system respectively. If the temperature falls below the temperature limit, MIXIT will react by fully opening the valve in order to circulate water in the system.

The return flow temperature is measured by the sensor in port B of MIXIT.

## Pump control modes

When MIXIT is connected to the pump, the control mode is by default set to the control mode that best suits the application in which MIXIT operates. In all MIXIT applications, you can choose between five different control modes:

- **AUTOADAPT**  
During operation, the pump automatically makes the necessary adjustment to the actual system characteristic. Recommended for most heating systems.
- **Proportional pressure**  
Default control mode for radiator heating systems. Typically used in systems with relatively large pressure losses in the distribution pipes.
- **Constant pressure**  
Default control mode for underfloor heating systems. We recommend this control mode in systems with relatively small pressure losses such as underfloor heating systems.
- **Constant curve/constant speed**  
Default control mode for air handling units. The pump operates according to a constant curve and is suitable for systems where both a constant flow rate and a constant head are required.
- **Constant flow**  
The pump maintains a constant flow in the system independently of the head. We recommend that you use this control mode in air handling unit systems.

## Position control

The **Position control** function allows you to use an external electrical input signal to control the opening degree of the MIXIT valve between 0-100%. The valve position resolution is 150 steps to avoid unnecessary movement and wear of the valve.

You can invert the interpretation of the electrical input signal from the Grundfos GO Remote app. When the input signal type 0-10 V is inverted, 0 V will correspond to 100 % and 10 V will correspond to 0 %.

The **Position control** function can only be configured in Grundfos GO Remote. The external electrical input type can be configured as 0-10 V, 0-20 mA or 4-20 mA. Flow characteristics can be set to either linear or equal percentage valve opening.

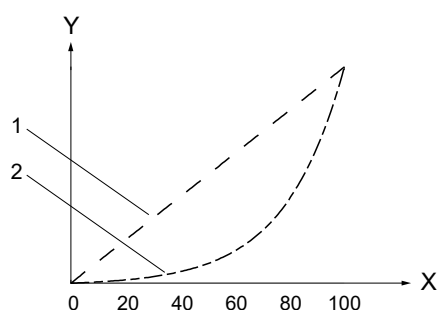

TM088571

Flow characteristics for linear (1) and equal percentage (2). X-axis: Valve position [%]. Y-axis: Flow [ $K_{vs}$ ].



When the **Position control** mode is active, the MIXIT functions listed below become inactive. Some of the inactive functions will still be visible and selectable in Grundfos GO Remote.

List of inactive functions, when **Position control** mode is active:

- Balancing limiters
- Coil preheat (for air handling unit systems)
- External setpoint reduction of 5 °C (for radiator heating systems)
- Frost protection in heating coil application (for air handling unit systems)
- Frost protection in cooling and combined application
- Grundfos BuildingConnect not support this function
- Periodic calibration
- Pressure independence for two-way valve
- Supply source setpoint
- Temperature controller: setpoint
- Temperature controller: gain (Kp) and integral time (Ti)
- Temperature controller: dead band for minimizing valve movement
- Eco schedule: temperature setback
- Underfloor overheat protection
- Warm weather shutdown
- Weather curve

## Weather curve

When the weather curve function is activated, MIXIT automatically adjusts the mixed flow temperature according to the outdoor temperature.

Weather curve is set by means of a five-point temperature curve. Weather curve is set by means of a five-point temperature curve. The curve allows you to predefine five liquid temperature setpoints. The five setpoints are set within an outdoor temperature range of -20 to +20 °C as default. However, it is possible to customize the weather curve and expand the outdoor temperature range to -60 to +60 °C as shown below.

MIXIT interpolates between the setpoints and automatically adjusts the liquid temperature accordingly to compensate for the energy demand for heating or cooling. For heating-coil applications, the curve defines the air temperature.

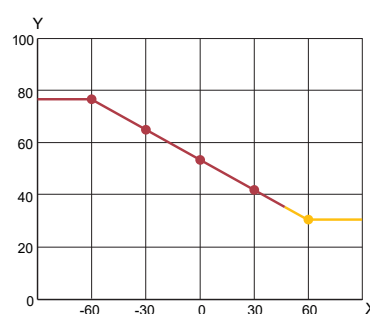

TM072831

Example of five point temperature curve. Y-axis: Setpoint [°C]. X-axis: Outdoor temperature [°C].

## Eco schedule

In some applications it can be useful to predefine a start and stop schedule and apply an automatic temperature setback function in order to minimize consumption, and thereby energy costs.

With the Eco schedule you can configure start and stop intervals on a weekly basis as well as set single events.

### Temperature setback and system turn off

You can define a temperature setback for the period in which MIXIT runs on Eco schedule. In this period, MIXIT sets the normal operation temperature back with the number of degrees set in Grundfos GO Remote. MIXIT can also be set to turn off during the Eco period.

## Warm weather shutdown

When a defined average outdoor temperature has been surpassed one to three days in a row, MIXIT automatically closes the valve and the pump stops. MIXIT and the pump start again, when the average outdoor temperature drops below the defined limit.

The temperature limit and number of days are set in Grundfos GO Remote.

The temperature signal must be available from either an outdoor temperature sensor or fieldbus.

Once the function has been activated or the function settings have been changed, MIXIT will immediately act accordingly.

## Pressure independence

If the differential pressure varies on the primary side, the relation between the valve opening and the flow through the valve changes. These changes will affect the control performance and can result in slow temperature responses or fluctuating temperatures. By comparing the valve opening with the forward and return temperature measurements, MIXIT supports such changes, along with changes in the pump flow, supply temperature, and return temperature. This allows the system to perform optimally, which increases both comfort and energy efficiency.

This function is available with the MIXIT DYNAMIC unit variant and with the DYNAMIC upgrade.

## Supply flow limit

To ensure sufficient primary flow to all installed MIXIT systems, you can balance each system according to its heat demand. This is done by limiting the primary flow through the valve.

As illustrated below, the primary flow of the valve ( $Q_{max}$ ) is adjusted to the maximum flow of the system (1). Hereby a new working range (2) is set for the valve. The working range is configured during setup without any mechanical adjustments.

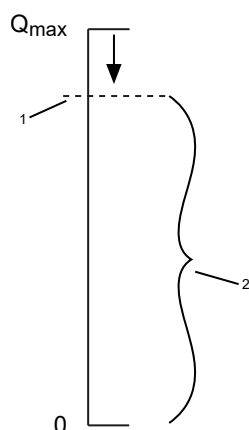

TM072799

Pos.	Description
1	Balanced maximum flow, system
2	New working range for valve

The valve is adjustable within its flow range ( $K_{VS}$  value). The flow ranges and  $K_{VS}$  values for each MIXIT variant are listed in the table in the performance range section.

This function is available with the MIXIT DYNAMIC unit variant and with the DYNAMIC upgrade.

If the CONNECT upgrade is installed, the primary flow data can be provided to a building automation system for monitoring purposes.

### Related information

#### [2. Performance range](#)

## Return temperature limit

Return temperature limit is commonly used to keep a high efficiency at the heat source and to protect the production plant.

The integrated temperature sensor in MIXIT monitors the return temperature. By using the return temperature limit function, you are able to keep the temperature below a set limit for heating and above a set point for cooling.

This function is available with the MIXIT DYNAMIC unit variant and with the DYNAMIC upgrade.

## Thermal power limit

MIXIT can be configured to limit the thermal power delivered by the mixing loop. The power limiter automatically limits the valve opening whenever the configured power limit is exceeded.

This function is available with the MIXIT DYNAMIC unit variant and with the DYNAMIC upgrade.

## Differential temperature limit

MIXIT can be configured to limit the temperature difference between the primary supply and return flow. This is especially useful in district heating where the payment tariff is often based on the differential temperature.

This function is available with the MIXIT DYNAMIC unit variant and with the DYNAMIC upgrade.

## Supply source setpoint

The supply source setpoint function makes it possible to control the output temperature from the supply source, such as the boiler in a heating system or the compressor in a cooling system. The benefit of controlling the supply source temperature is to reduce the energy loss in the pipes by limiting the difference between the output temperature from the supply source and the temperature needed in the load.

The supply source setpoint can be configured for either one MIXIT unit or a daisy chain of multiple MIXIT units connected in series.

The configuration is made via Grundfos GO Remote where you can offset the MIXIT setpoint for heating or cooling:

- Supply source setpoint = MIXIT setpoint plus 5 °C as default for heating.
- Supply source setpoint = MIXIT setpoint minus 2 °C as default for cooling.

### Daisy chain

When multiple MIXIT units are connected in series, you can connect the analog output of one MIXIT unit to the analog input of another MIXIT unit and then enable the **Daisy chain** functionality.

All MIXIT units must run the same application type for the function to work. The setpoints of the connected MIXIT units are compared and if they differ, the function will select the maximum value in heating applications and the minimum value in cooling applications as the MIXIT setpoint. The resulting setpoint of the comparison is then sent out on the analog output.

All the connected MIXIT units must use the same application, that is, either heating, cooling or combined heating and cooling. In the combined heating and cooling application, make sure to use the same digital input signal, so that all the connected MIXIT units switch application simultaneously.



CIO2 is not available for air temperature feed back, when using **Daisy chain** for supply source setpoint.

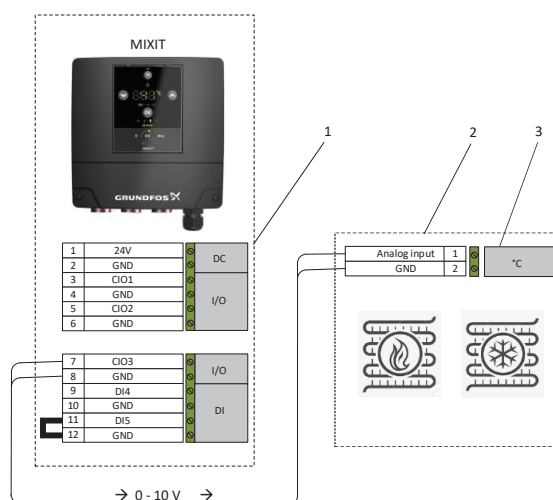

Supply source setpoint configuration of one MIXIT unit

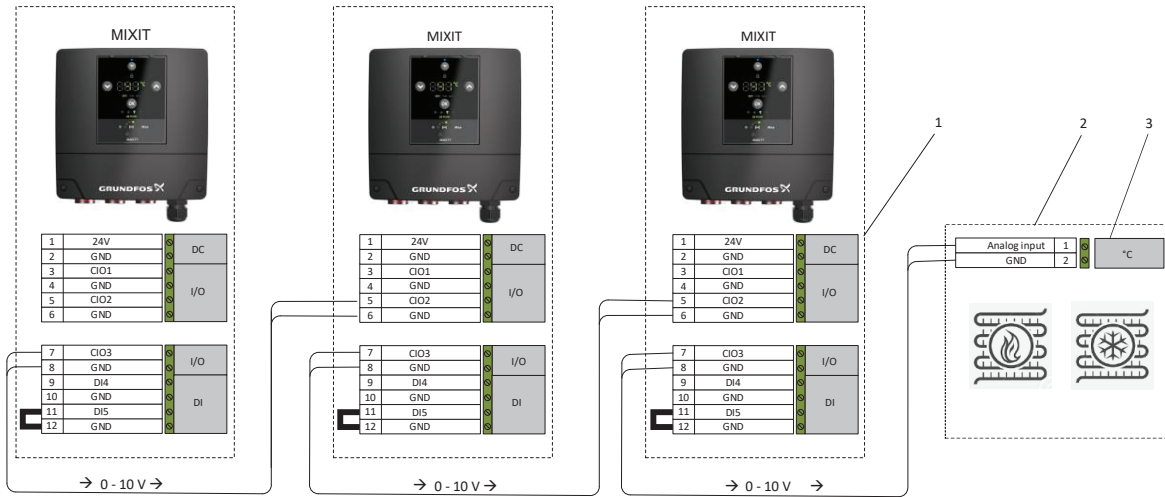

TM086153

Supply source setpoint configuration of a daisy chain

Pos.	Description
1	MIXIT terminals for analog input and output.
2	Supply source terminals for analog input.
3	Supply source setpoint [°C].
I/O	Configurable Input/Output.
DI	Digital input.

**Related information**

[Setting up MIXIT using Grundfos GO Remote](#)

## Energy monitoring

This function is available with the MIXIT DYNAMIC unit variant and with the DYNAMIC upgrade.

The energy monitoring function makes it possible to monitor the energy consumption in individual zones. This function does not require any additional sensors or additional settings to the system.

These are calculated values which cannot be used for billing purposes. However, this function is perfect for optimization purposes in order to prevent excessive energy costs caused by system imbalances.

The Energy monitoring function includes:

- **Current values** for the system in use, that is, either heating or cooling values.
- **Year to date** counter, available for Grundfos GO Remote.
- **Last year** counter, available for Grundfos GO Remote.
- **Lifetime total** counter, available for Grundfos GO Remote, fieldbus and Grundfos BuildingConnect.

### Energy monitoring display in Grundfos GO Remote

The values in the energy monitoring display reflect the actual status of the system in use, that is, either heating or cooling. In the combined heating and cooling application, you can switch between the heating and cooling display. If currently heating, Grundfos GO Remote shows the heating parameters and vice versa.



TM082953

Energy monitoring display in a heating application

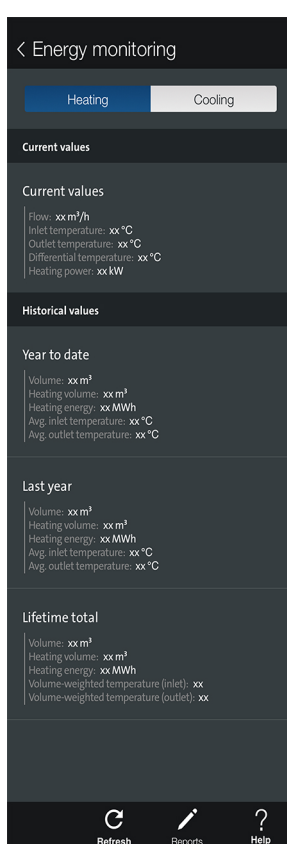

Energy monitoring display in a combined heating and cooling application

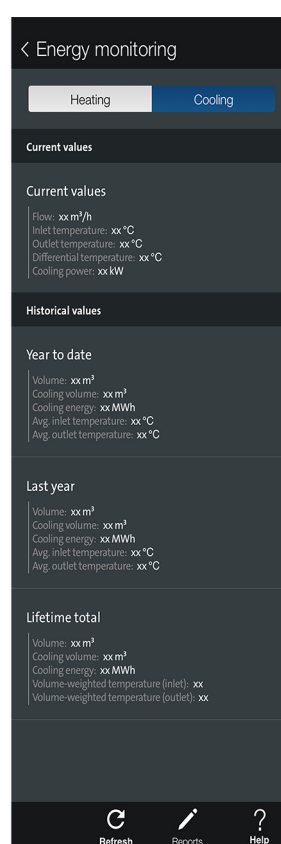

TM082954

### Calculated value for thermal power

The thermal power is calculated based on the measurements from the two temperature sensors  $T_1$  and  $T_2$  and the flow sensor. At normal working conditions the tolerance of the thermal power is +/- 10% relative to the operating point. However, some conditions can influence the thermal power:

- **Low supply flow.** The built-in flow sensor has a minimum flow limit for measuring flow and below this limit the flow is estimated based on the temperature measurements and the flow estimation from the pump.
- **Low temperature difference.** The temperature sensors are not paired, so the tolerance on the temperature measurements will be more dominant at low temperature difference. The tolerances of the flow and temperature measurements can be found in section on sensor data.

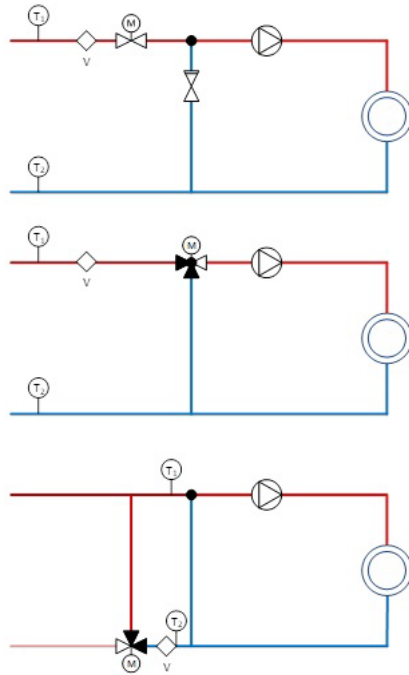

TM086353

MIXIT hydraulic configurations placement of sensors

**Energy monitoring registers**

The table below shows the energy monitoring registers and which counter functions are available for Grundfos GO Remote, fieldbus and Grundfos BuildingConnect.

Register name	Content	Lifetime			Last year / Year to date		
		Grundfos GO Remote	Fieldbus	Grundfos Building-Connect	Grundfos GO Remote	Fieldbus	Grundfos Building-Connect
Heat Volume $V_H$	$\Sigma V_H$	•	•	•	•		
Cooling Volume $V_C$	$\Sigma V_C$	•	•		•		
Heat Energy	$\Sigma V_H (T_1 - T_2) \rho C_p^{3)}$	•	•	•	•		
Cooling Energy	$\Sigma V_C (T_2 - T_1) \rho C_p^{3)}$	•	•		•		
Volume weighted average T1, Heating (inlet)	$\Sigma V_H T_1$	•	•	•	•		
Volume weighted average T2, Heating (outlet)	$\Sigma V_H T_2$	•	•	•	•		
Volume weighted average T1, Cooling (inlet)	$\Sigma V_C T_1$	•	•		•		
Volume weighted average T2, Cooling (outlet)	$\Sigma V_C T_2$	•	•		•		

3) The actual implementation calculates uses enthalpy.

**Example of calculated values for average temperatures using yearly readings**

Reading date	Volume $(V_H)$	Volume weighted average T1, Heating (inlet)	Average of inlet	Volume weighted average T2, Heating (outlet)	Average of outlet
		$(\Sigma V_H T_1)$	$(V_H) / (\Sigma V_H T_1)$	$(\Sigma V_H T_2)$	$(V_H) / (\Sigma V_H T_2)$
01-07-2022	534.3	48236	-	18654	-
01-07-2021	236.9	20123	-	7651	-
<b>Yearly consumption</b>	<b>297.4</b>	<b>28113</b>	<b>94.5</b>	<b>11003</b>	<b>37.0</b>

**Related information**

[Sensor data](#)

## Grundfos BuildingConnect

With Grundfos BuildingConnect you can monitor your MIXIT system from the office or on the go. Grundfos BuildingConnect offers realtime monitoring, including alarm and warning notifications.

With Grundfos BuildingConnect Professional you get access to even more monitoring points and trend curves as well as the ability to control the system.

## Fieldbus integration

The integrated fieldbus makes it easy to incorporate MIXIT into any building management system (BMS). MIXIT provides all data points through one data connection because the valve, pump, controller and sensors are one complete system. No I/O is required in the sub controller, and if the integrator uses an IP-based fieldbus, the sub controller is redundant.

Furthermore, the integrated fieldbus offers:

- A cost-effective installation due to less wiring
- Data points delivering all available objects from MAGNA3/TPE3 and MIXIT
- Performance/response tests offsite
- Offsite balancing and optimisation without having to manually change valve positions
- Logging of parameters such as:
  - supply temperature, mixed temperature and return temperature
  - flow estimation
  - valve position
  - power estimations
  - warnings and alarms.

The integration can be done via BACnet IP, BACnet MS/TP, Modbus TCP or Modbus RTU. The connectivity is configured via the Grundfos GO Remote app. When the fieldbus connection is established, the remaining configuration can be done via the bus system setup.

### Built-in line termination

If MIXIT is the last device on the fieldbus cable, a built-in terminal resistor can be activated via an on/off switch to avoid noise on the cable. Note that this only applies to BACnet MS/TP and Modbus RTU connections.

## Functional profiles

There are two functional profile documents available for MIXIT covering all four fieldbus connections.

The documents are available via:

- Grundfos Product Center: <http://product-selection.grundfos.com>.
- Grundfos EICA selection tool for all fieldbus related documents: <http://www.grundfos-eica.com>.

Document	Product number	Grundfos Product Center
BACnet for Grundfos MIXIT (BACnet IP, BACnet MS/TP)	99258495	 <a href="http://net.grundfos.com/qr/i/99258495">http://net.grundfos.com/qr/i/99258495</a>
Modbus for Grundfos MIXIT (Modbus TCP, Modbus RTU)	99349159	 <a href="http://net.grundfos.com/qr/i/99349159">http://net.grundfos.com/qr/i/99349159</a>

## Related information

[System integration](#)

[Terminal connections overview](#)

[Setting up MIXIT using Grundfos GO Remote](#)

## 7. Installation

MIXIT allows you to build a complete mixing loop in only two steps.

1. Install MIXIT and the pump in the pipe system.  
You can suspend both units directly in the pipes, provided that the units are not stressed by the pipes.

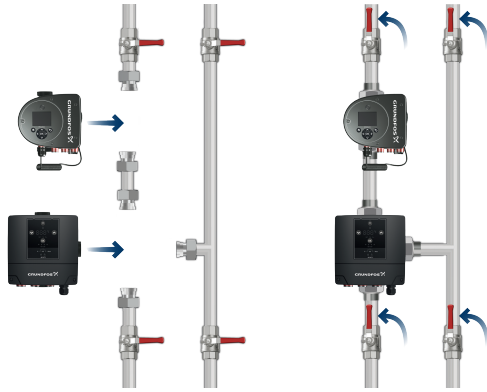

Installing the threaded MIXIT version in the pipes

TM071471

2. Connect MIXIT and the pump to the power supply.  
Once connected, the installation of MIXIT is complete.

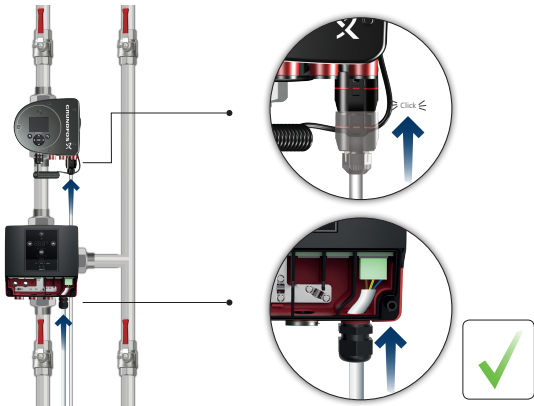

TM071472

### Insulating shells

MIXIT includes insulating shells that are applicable for both heating and cooling installations.

### Electrical installation

All electrical connections must be carried out by a qualified electrician in accordance with local regulations.

- The system must be connected to an external main switch.
- The system must always be correctly earthed.
- The system requires no external motor protection.
- The system incorporates thermal protection in order to prevent slow overloading and blocking.

MIXIT has a digital input that can be used for external control of start/stop of both the pump and MIXIT without switching the power supply on/off. We do not recommend that the pump is started and stopped on its own without MIXIT being started and stopped as well.

### Related information

[Cable requirements](#)

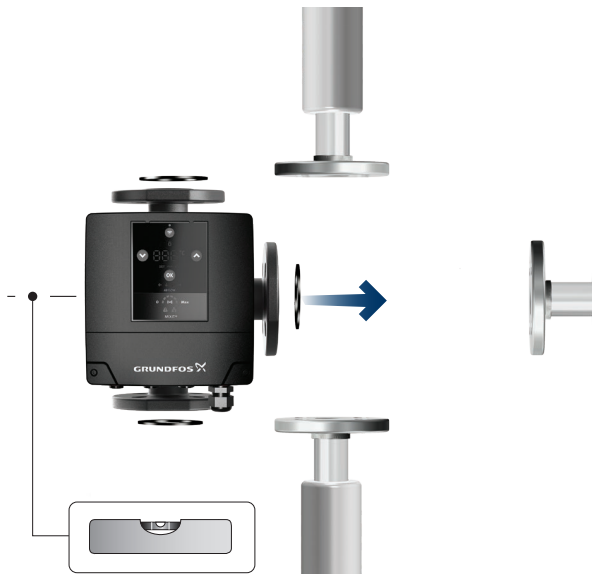

Installing the flanged MIXIT version in the pipes

TM080490

## Orientation of the B port

The MIXIT valve unit and the pump are most often mounted in line. MIXIT can be installed in horizontal or vertical position, depending on the orientation of the B port and the direction of the supply flow.

The figure below shows the different installation options related to the orientation of the B port. The arrows indicate the direction of the supply flow.

- Top: Left-oriented B port.
- Bottom: Right-oriented B port.

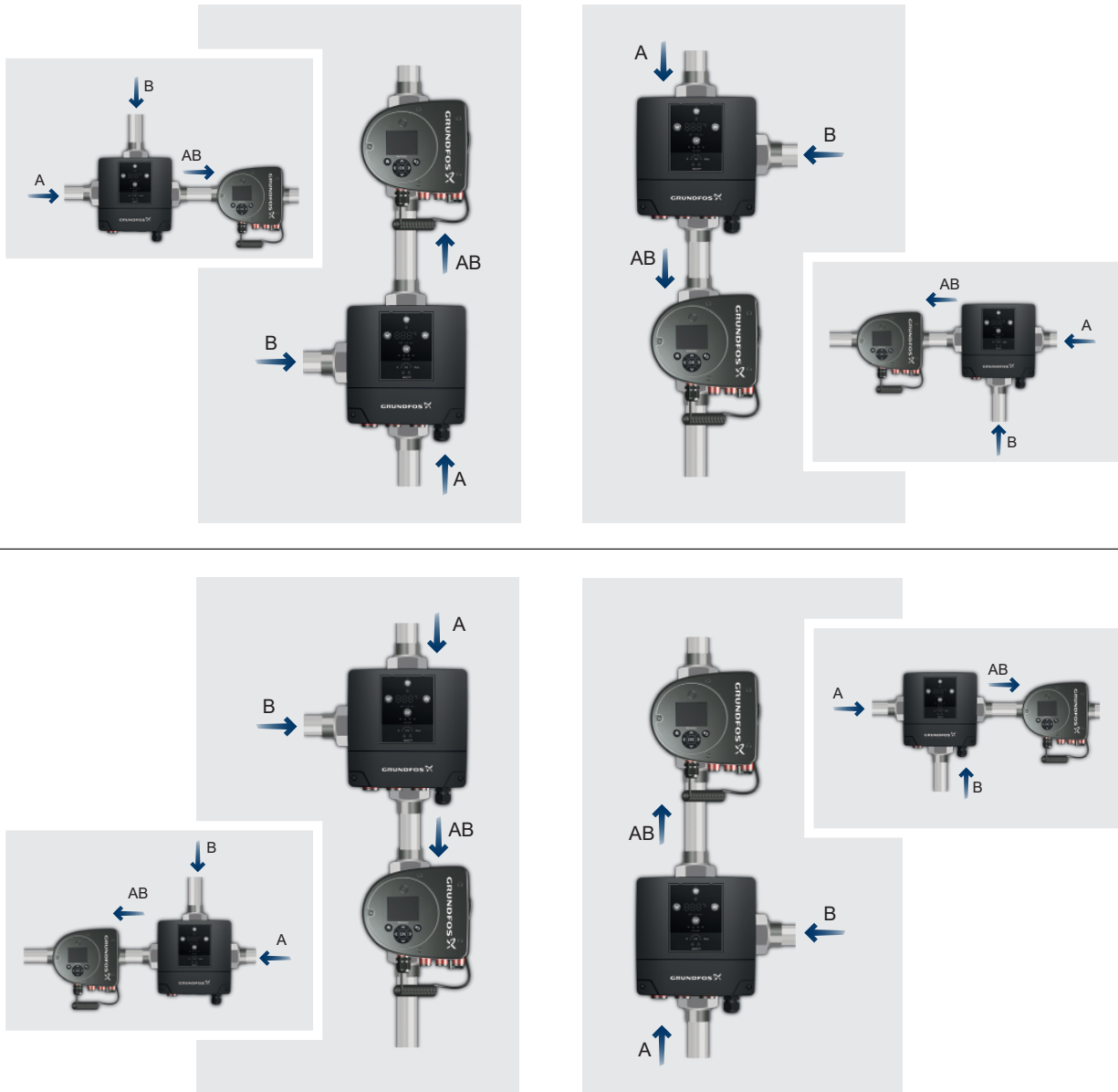

TM071474

### Related information

#### 2. Performance range

## Terminal connections overview

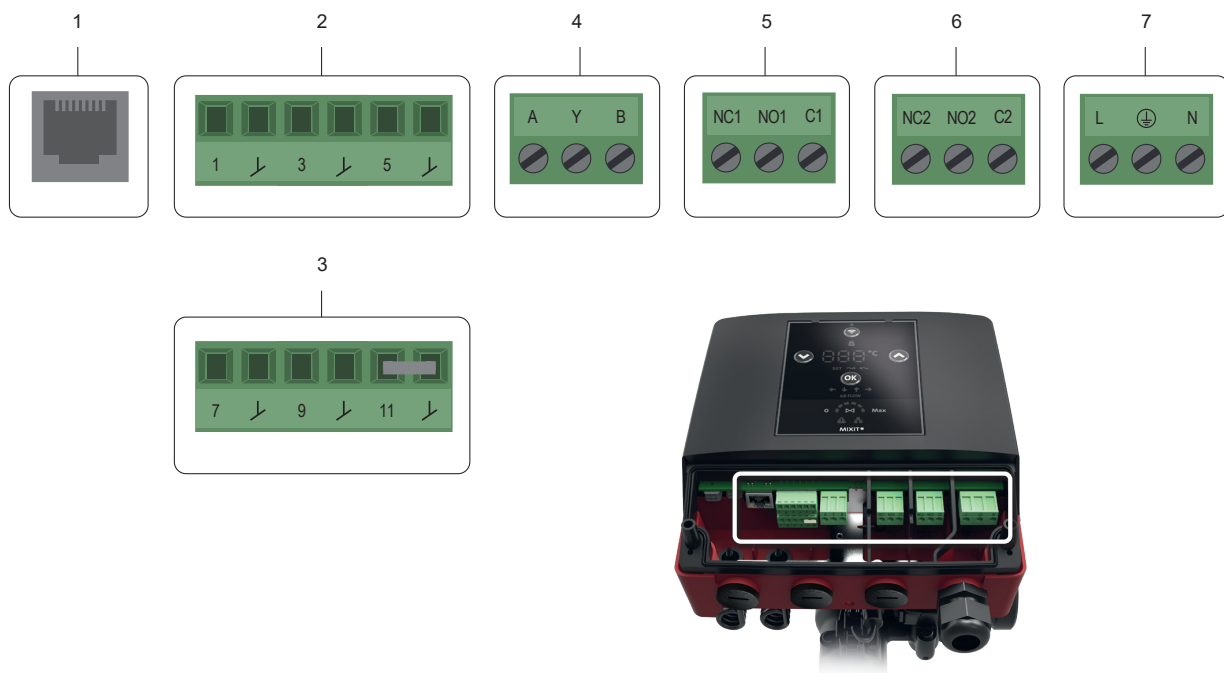

TM071470

Pos.	Description
1	Ethernet RJ45 (BACnet IP, Modbus TCP, Grundfos BuildingConnect)
2	Configurable I/O
3	Configurable I/O
4	RS-485 transceiver (BACnet MS/TP, Modbus RTU)
5	Relay 1
6	Relay 2
7	Mains supply. Carry out the electrical connection and protection according to local regulations.



The terminals are coded in such a way that the relay terminal plugs cannot be used in the RS-485 input and the configurable inputs and outputs cannot be switched around.

### Related information

[MIXIT in a radiator heating system](#)

[MIXIT in an underfloor heating system](#)

[MIXIT in an air handling unit system](#)

[Fieldbus integration](#)

## 8. Operating the product

### Operating panel for MIXIT

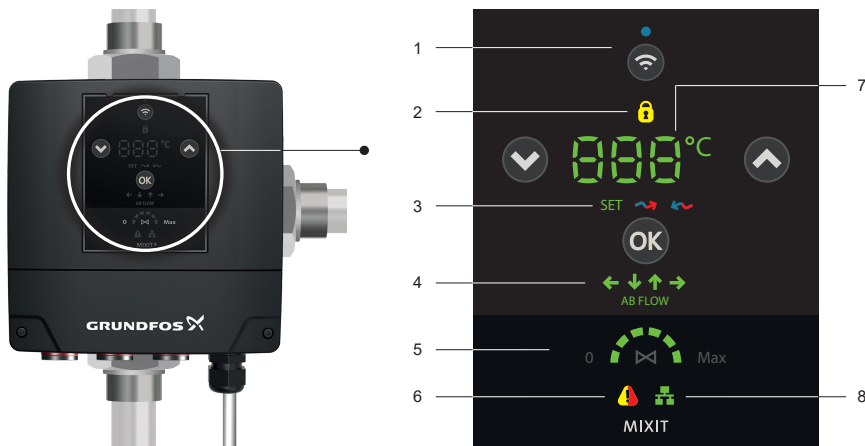

TM071469

Pos.	Description	
1	Connect button for connecting the valve unit with the pump and connecting MIXIT with Grundfos GO Remote.	When MIXIT tries to establish contact with either the pump or Grundfos GO Remote, the blue LED flashes. Once connection is established, the LED is permanently on.
2	Locked operating panel	This indicates that the operating panel is locked. The panel can be locked and unlocked using Grundfos GO Remote. The locked panel prevents unauthorized changes to the settings, but you can still use the <b>OK</b> button to view the temperature indications.
3	Temperature indication (setpoint, supply or return temperature) <b>Default mode:</b> None of the three LEDs are lit. The temperature shown is the mixed flow temperature or, in heating coil applications, the air temperature. <b>Combined mode:</b> The default setting is heating. Switching between heating and cooling is controlled by a digital input (DI4) or by the fieldbus.	Indicates which temperature is shown on the display (7). Press the <b>OK</b> button to toggle between the following: <ul style="list-style-type: none"> <li>• <b>SET:</b> Setpoint. Shows the current setpoint. Indicates that the setpoint is being or can be adjusted. Use the <b>Up</b> and <b>Down</b> buttons to adjust the setpoint.</li> <li>• <b>Arrow pointing right:</b> Supply temperature. Lights red in heating systems, blue in cooling systems.</li> <li>• <b>Arrow pointing left:</b> Return temperature. Lights blue in heating systems, red in cooling systems.</li> </ul> The display returns to its default mode after 12 seconds.
4	AB port orientation	This indicates the orientation of the AB port (flow outlet).
5	Valve position	This indicates to which degree the valve is open. <b>0</b> means that the valve is closed. <b>Max</b> means that the valve is fully open. If a $K_{vs}$ value is configured, this limit will be <b>Max</b> on the operating panel.
6	Warning and alarm indication	Yellow indicates a warning. The system continues to operate. When a warning occurs, press and hold the <b>OK</b> button, until the fault code is presented in the display. Red indicates an alarm. The system stops operating.
7	Temperature or fault code <b>Default mode:</b> The mixed flow temperature is shown. In heating coil applications, the air temperature is shown.	The display shows: <ul style="list-style-type: none"> <li>• Temperature setpoint. Use the <b>Up</b> and <b>Down</b> buttons to adjust the setpoint.</li> <li>• Inlet, outlet or mixed flow temperature (3).</li> <li>• Fault codes. The LEDs will shift between <b>Err</b> and the fault code.</li> </ul>
8	External control	This indicates that MIXIT is being controlled or monitored by external communication equipment.



Once the pump and MIXIT are connected, MIXIT takes control of the pump and the operating panel of the pump is now locked. Settings to the system are done via Grundfos GO Remote and the operating panel of MIXIT.

#### Related information



[Starting up the system](#)



[Warnings and alarms](#)

## Starting up the system

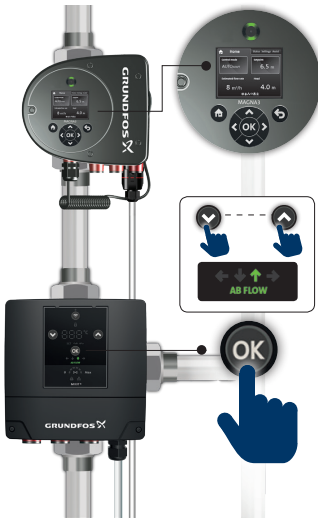
Once powered up, the pump and the MIXIT unit can be started. Starting up the product is done in four simple steps.

### Starting up the system with a MAGNA3 pump

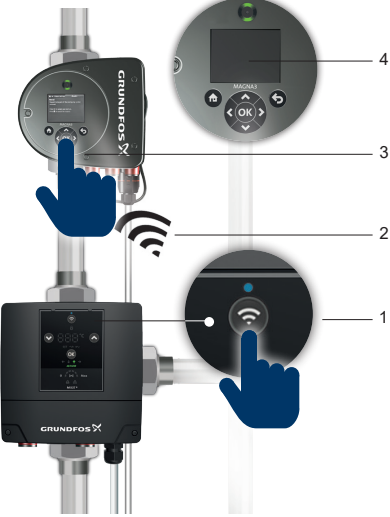
Step 1	Step 2
<p><b>Set AB port orientation</b></p> <p>Use the <b>Up</b> and <b>Down</b> buttons on the MIXIT operating panel to set the AB port flow orientation and press <b>OK</b>.</p>  <p style="text-align: right;">TM071477</p>	<p><b>Configure the pump</b></p> <p>Set the pump by completing the startup wizard.</p>  <p style="text-align: right;">TM071475</p>

Step 3	Step 4
<p><b>Connect the pump and the MIXIT unit</b></p> <p>By pressing the connectivity button on the MIXIT operating panel (1), MIXIT tries to establish contact with the pump (2). Confirm by pressing the <b>OK</b> button on the pump (3). The pump's display turns off after approximately 20 minutes (4).</p>  <p style="text-align: right;">TM071476</p>	<p><b>Set temperature setpoint</b></p> <p>Use the <b>Up</b> and <b>Down</b> buttons on the MIXIT operating panel to adjust the desired temperature setpoint. Press <b>OK</b> to complete the setup.</p>  <p style="text-align: right;">TM071478</p>

## Starting up the system with a TPE3 pump

### Step 1

#### Set AB port orientation

Use the **Up** and **Down** buttons on the MIXIT operating panel to set the AB port flow orientation and press **OK**.



TM080492

### Step 2

#### Configure the pump

Set the pump by completing the startup wizard.



TM080493

### Step 3

#### Connect the pump and the MIXIT unit

By pressing the connectivity button on the MIXIT operating panel (1), MIXIT tries to establish contact with the pump (2). Confirm by pressing the **OK** button on the pump (3). The pump's display turns off after approximately 20 minutes (4).



TM080494

### Step 4

#### Set temperature setpoint

Use the **Up** and **Down** buttons on the MIXIT operating panel to adjust the desired temperature setpoint. Press **OK** to complete the setup.



TM080496



TM080495

How to set up MIXIT in the system is described in more detail in the separate MIXIT installation and operating instructions available in Grundfos Product Center. Link: <http://net.grundfos.com/qr/i/99513532>.

### Related information

[Operating panel for MIXIT](#)

## Temporary heating

MIXIT supports the use of temporary heating to dehumidify new buildings, so that they can dry out while they are still under construction.

MIXIT is ready to operate after the initial startup of the system. Any additional wiring for MIXIT can be completed later, and the final setup is done via Grundfos GO Remote.

## Setting up MIXIT using Grundfos GO Remote

The Grundfos GO Remote app is free of charge and available for iOS and Android devices for your smartphone or tablet.

Once the initial start up of the MIXIT unit and pump is completed, MIXIT is connected with the Grundfos GO Remote app via Bluetooth.



TM071468

Once connected, a wizard helps you set up your MIXIT system. The wizard lets you:

- turn on temporary heating
- define the application and circuit type
- choose whether MIXIT must operate as a two- or three-way valve
- set the pump's control mode, head and flow duty point
- define sensor inputs.

Once the setup wizard is completed, you can set the functionalities available according to your chosen circuit type. You can upgrade to MIXIT DYNAMIC or CONNECT at any time via Grundfos GO Remote.

### Monitoring MIXIT

Grundfos GO Remote allows you to monitor the system live, including:

- inputs from sensors
- mixed flow temperature and return temperature
- pump status
- valve status
- energy monitoring.

### Fieldbus connection

If MIXIT is integrated into a building management system, the connectivity is configured via Grundfos GO Remote. When the fieldbus connection is established, the

remaining configuration can be done via the bus system setup. Fieldbus connection requires that the CONNECT upgrade is activated.

### Supply source set point

After the initial startup of the MIXIT unit and the pump is completed, you can set the supply source setpoint. The supply source setpoint can be configured for either one MIXIT unit or a daisy chain of multiple MIXIT units connected in series.

The configuration is made via Grundfos GO Remote where you can offset the MIXIT setpoint for heating or cooling:

- Supply source setpoint = MIXIT setpoint plus 5 °C as default for heating.
- Supply source setpoint = MIXIT setpoint minus 2 °C as default for cooling.

Grundfos GO Remote will guide you on how to define setpoint output type and range, how to connect the analog output cable to MIXIT, and how to define heating or cooling offset and standby temperature. If required, enable the Daisy chain feature.

### Related information

- [System integration](#)
- [Supply source setpoint](#)
- [Fieldbus integration](#)

## Warnings and alarms

If MIXIT detects a warning or an alarm, it will be highlighted on its operating panel via the yellow (warning) and red (alarm) LED. The operating panel uses the LEDs of the temperature setpoint to show the error code. See the section on the operating panel for MIXIT.

The **Alarms and warnings** menu in Grundfos GO Remote describes the fault and lets you reset it when it has been corrected. This menu also keeps a log of previous warnings and alarms.

### Related information

- [Operating panel for MIXIT](#)

## Firmware updates

MIXIT firmware is updated via Grundfos GO Remote.

If online and connected to MIXIT, the app automatically notifies the user about available updates. To update the firmware, simply follow the instructions in Grundfos GO Remote.

## 9. Operating conditions

### Location

The product is designed for indoor installation. Always install the product in a dry environment where it will not be exposed to drops or splashes of liquid from surrounding equipment or structures, for example condensing water.

The product contains parts of stainless steel. Therefore it is important to avoid direct installation in aggressive environments such as:

- Indoor swimming pools, where the product is exposed to the ambient environment of the pool
- locations with direct and continuous exposure to a marine atmosphere
- locations where hydrochloric acid (HCl) can form acidic aerosols, for example when acid escapes from open tanks or from frequently opened or vented containers.

The above applications do not disqualify for installation of the product. However, it is important that the product is not installed directly in these environments.

### Maximum distance between MIXIT and the pump

We recommend a maximum distance of 0.5 m between MIXIT and the pump to ensure optimal performance at low load.

### Minimum space

MIXIT requires a minimum space on all sides of the product. The required clearance on the installation site is shown below.

Description	Clearance [mm]
Top and bottom	200
Left and right	100
Front and rear	100



TM075945

### Ambient conditions

Ambient temperature during operation	0-50 °C
Ambient temperature during storage and transport	-40 to +70 °C
Relative humidity	Maximum 95 %

### Maximum operating pressure

PN 6/10	6/10 bar / 0.6/1.0 MPa
PN 10	10 bar / 1.0 MPa

During normal operation, MIXIT must not be used at higher pressures than those indicated on the Valve nameplate.

### Pumped liquids

The product is suitable for mixing clean, thin, non-aggressive and non-explosive liquids without solid particles or fibres.

The liquid temperature must be between 0 and 90 °C, not freezing or boiling. For short periods the temperature can be up to 110 °C, provided that the media is in a liquid state and not boiling. Freezing and boiling the media must be prevented.

You can use the product for water, water-glycol-mixtures with up to 50 % glycol, or water-ethylene-mixtures with up to 50 % ethylene.

For the flow measurement to function effectively and precisely at all flows, the viscosity must be equal to or below 2 cSt.

In heating systems, the water must meet the requirements of the accepted standard on water quality in heating systems according to local regulations.

The product is not intended for drinking water.

### Radio communication

The radios of this product are placed in unlicensed bands and can be used without restrictions anywhere in the EU member states.

The MIXIT unit has two radio signals; GLoWPAN and Bluetooth.

The Grundfos proprietary wireless signal GLoWPAN is used for communication between MIXIT and the pump, while the Bluetooth Low Energy (BLE) radio is used for communication between MIXIT and Grundfos GO Remote.

## 10. Technical data

### Type key

Example: MIXIT 25-10 R NRV

Example: MIXIT DYNAMIC 32-16 L F

Codes	Key to codes
MIXIT	Type range.
[ ]	Variant including standard functionalities.
DYNAMIC	Variant including both standard and DYNAMIC upgrade functionalities.
25 32 40 50	Nominal diameter (DN) of inlet and outlet ports [mm].
6.3 10 16 25 40	$K_{vs}$ value.
R	Right-oriented B port.
L	Left-oriented B port.
[ ]	Threaded pipe connection type.
F	Flanged pipe connection type.
<i>Hydraulic accessories:</i>	
[ ]	Without non-return valve.
NRV	With non-return valve (factory fitted).

### Related information

[MIXIT valve unit](#)

### Cable requirements

Cable type: H05RN-F / H07RN-F

All control terminals are supplied by safety extra-low voltage (SELV) and separated.

All cables used must be heat-resistant up to at least 70 °C.

All cables used must be installed in accordance with EN 60204-1 and EN 50174-2:2000.

Use cable clamps and double insulated cables for relays.

Terminal	Cable	Cable cross section [mm <sup>2</sup> ]	Torque [Nm]
I/O terminals	Screened cable	0.5 - 1.5	0.2
AC supply	Cable	0.75 - 1.5	0.5
RS-485	Screened 3-core cable	0.5 - 2.5	0.5
Relay 1 and 2	Screened cable	0.5 - 2.5	0.5

### Cable length

Speed [Mbit/s]	Cable type	Max. cable length [m (ft)]
10	CAT5	100 (328)
100	CAT5e	100 (328)

### Related information

[Electrical installation](#)

### Electrical data

All specified voltages refer to GND. GND is internally connected to protective earth.

Supply voltage	1 x 230 V ± 10 %, 50 Hz, PE
Protective class	I
Maximum power	15 W
Minimum power	2.5 W
Nominal power	8 W
Rated impulse-withstand voltage	4 kV
Short-circuit current rating	500 A
Overvoltage category (OVC)	III
Pollution degree	2

### Inputs and outputs

#### Absolute maximum voltage and current limits

Relay 1 and 2, maximum contact load	250 VAC or 30 VDC, 2 A
RS-485 terminal	-5.5 to +9.0 VDC, else < 25 mADC
Other I/O terminals	-0.5 to +26 VDC, else < 15 mADC

Exceeding the electrical limits may result in severely reduced operating reliability and product life.

#### Digital input (DI)

Internal pull-up current	> 10 mA at $V_i = 0$ V, $R_i = 100$ k $\Omega$ at $V_i > 5$ V
Certain low logic level	$V_i < 1.8$ V
Certain high logic level	$V_i > 2.7$ V or floating
Hysteresis	Yes

The I/Os, CIO and DI, are 24 V tolerant.

#### Relay outputs

Potential-free changeover contacts (SPDT)	
Contact ratings	250 VAC, 2 A, 50/60 Hz, AC-1 (resistive)
Action type	1.B (micro disconnection)
Minimum contact load when in use	5 VDC, 10 mA

#### Analog input (AI)

Voltage mode range	0-10 V
Voltage mode	$R_i = 100$ k $\Omega$
Current mode range	4-20 mA
Current mode	$V_{in}$ (appr.) = $lin * 50 \Omega + 1$ V
Current mode overload protection	Yes, current limit > 75 mA
Measurement tolerance	± 3 % of full scale

#### Analog output (AO)

Sourcing capability only	
Voltage mode range	0-10 V
Min. load between AO and GND	3 k $\Omega$
Short-circuit protection	Yes
Current mode range	4-20 mA

Voltage drive capability	10 V at 20 mA
Open-circuit protection	Yes
Tolerance	± 5 % of set value

#### Pt1000 input (PT)

Temperature measurement range	-30 to +180 °C
Measurement tolerance	± 1.5 °C
Measurement resolution	0.15 °C

#### Power supplies (24 V)

Output voltage	-24 VDC ± 5 %
Max. current	100 mA DC (sourcing only)
Overload protection	Yes

#### Bus input (RS-485)

Protocols	BACnet MS/TP, Modbus RTU
Supply voltage	5 VDC ± 5 %, I <sub>max</sub> 350 mA

#### Bus input (Ethernet)

Protocols	BACnet IP, Modbus TCP
Cable type, BACnet IP	Standard CAT5, CAT5e or CAT6
Cable type, Modbus TCP	Standard CAT5, CAT5e or CAT6

## Classes

Temperature class	TF110 (EN 60335-2-51)
Enclosure class	X4D (EN 60529)

## Sound pressure level

The sound pressure level for MIXIT without cavitation is below 40 dB(A) (pressure differential across the valve A - AB < 100 kPa).

## Actuator

Ball valve, movement and type of action	Angular rotation, 360° both ways Multi-position
Temperature for ball pressure test	125 °C
Maximum rated mechanical load	15 Nm
Travel time	1 minute (90° / 15 seconds)
Limitation of operating time	1 second on / 4 seconds off

### Sensor data

Vortex flow sensor, port A	From 0.3 m <sup>3</sup> /h depending on the MIXIT variant with a dynamic range of 1:25.
Temperature range, port A and port B	-10 to +120 °C
Accuracy temperature, port A and port B	± 1.25 °C (-10 to +80 °C), ± 1.3 °C (80-90 °C), ± 2 °C (90-110 °C) Flow ratio, Q <sub>ab</sub> /Q <sub>a</sub> : 1.1 - 10.

### Flow sensor accuracy

The curves show how accurate the flow sensor measures the actual flow.

- $\mu$  shows the average value of all measured MIXIT units in the  $K_{vs}$  range (blue curves)
- $3\sigma$  and  $-3\sigma$  show that 99.7 % of all MIXIT units in the range will be within these accuracies (green and orange curves)

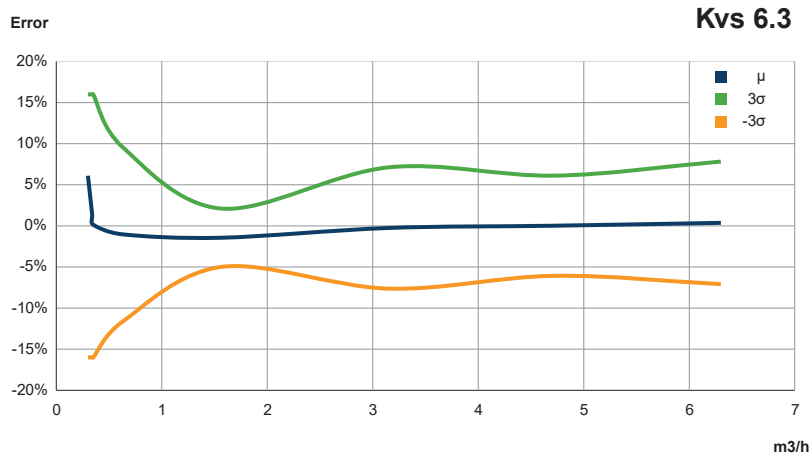

TM074191

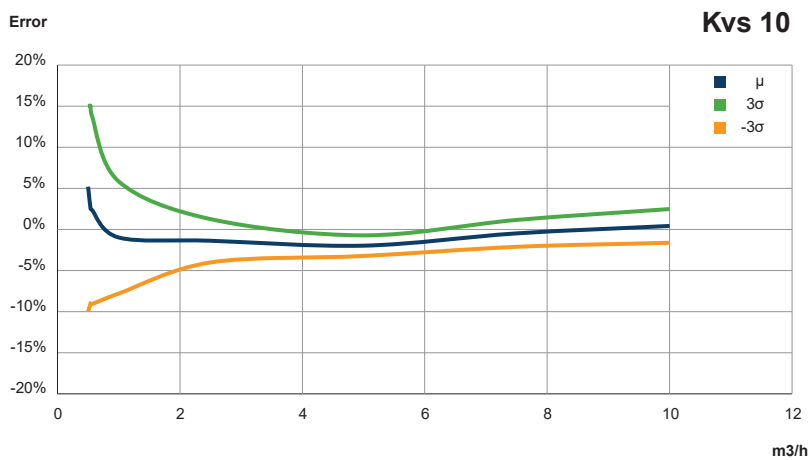

TM074192

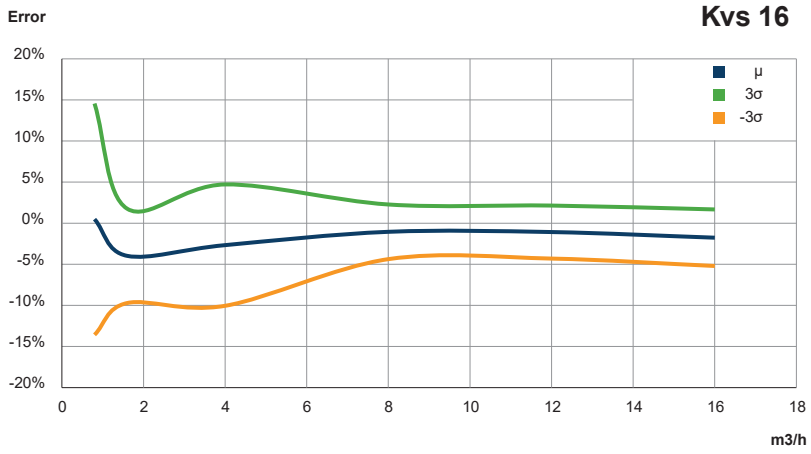

TM074193

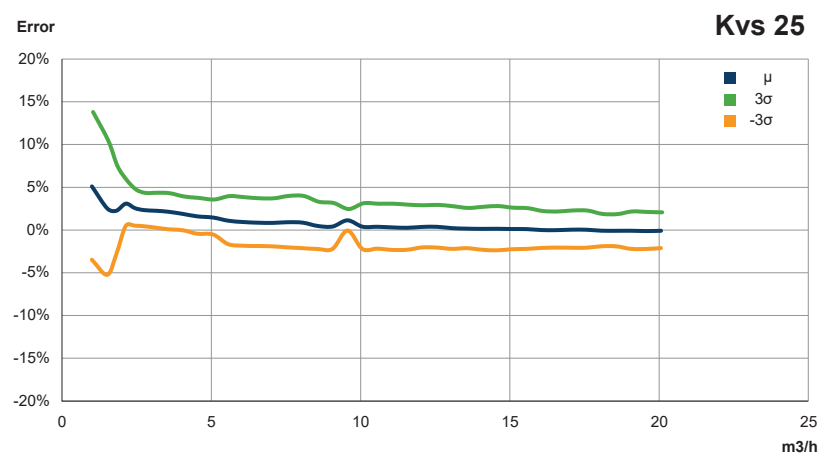

TM084341

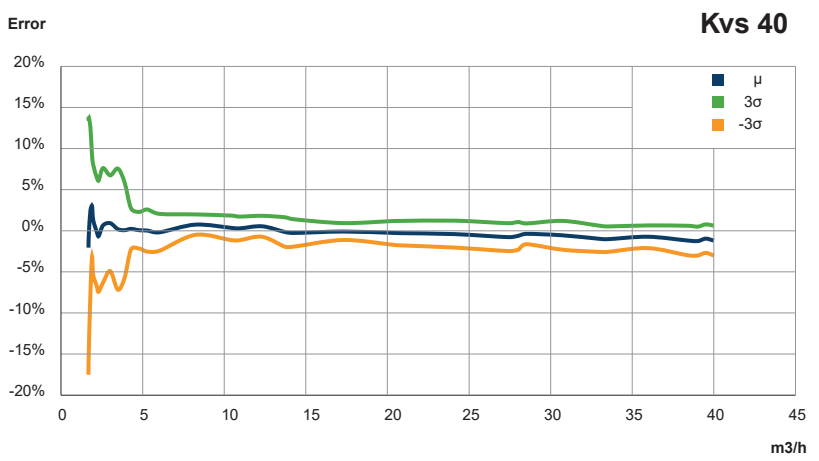

TM081910

**Related information**  
[Energy monitoring](#)

## Valve

### Valve details

Type of valve	Mixing valve
Function	Three-way inverting valve or two-way modulating valve with integrated shunt
Type of closure member	Ball
Type of operation	Directly controlled and operated, no minimum differential pressure
Type of movement	Rotational, no mechanical stops
Positioning	Modulating
Valve stroke (rated travel)	90 °
Position when de-energised	N/A, no fail-safe
Leakage	Port A: max. $5 \cdot 10^{-6} \cdot K_{VS}$ (according to EN 60534-4, class IV-S1) Port B: max. $10^{-3} \cdot K_{VS}$ (according to EN 60534-4, class III)

### Connections (Threaded version)

Number of ports	3
Type of end-connection	Externally threaded, ISO 228-1
Inner dimension of ports	DN size
Dimension of end-connection threads	DN 25 - G 1 1/2, DN 32 - G 2

### Connections (Flanged version)

Number of ports	3
Type of end-connection	Flange connection, EN 1092-2
Inner dimension of ports	DN size
Dimension of end-pipe connection	DN 32, DN 40, DN 50

### Size and capacity

DN size	Capacity [ $K_{VS}$ ]
DN 25-6.3	6.3
DN 25-10	10
DN 32-16	16
DN 40-25	25
DN 50-40	40

### Media and working conditions

Minimum temperature	0 °C, non-freezing
Maximum temperature	90 °C
Maximum temperature, short term	110 °C, non-boiling
Minimum differential pressure	0 bar
Maximum differential pressure for normal operation and close-off	2.5 bar
Maximum differential pressure for positioning	5 bar
Maximum differential pressure, not for normal operation	10 bar
Maximum rated working pressure (PS)	10 bar
Liquid types	Water Water-glycol-mixtures with up to 50 % glycol Water-ethylene-mixtures with up to 50 % ethylene
Not suitable for drinking water.	

### Wetted materials

Valve housing	Cast iron GJS500-7, CED coated
O-rings	EPDM (EP70)
Seats	Carbon reinforced PTFE
Ball	Brass CW614N, Ni and Cr plated
Other metal parts	Stainless steel

Friction discs	PTFE
Other plastic parts	PPS 40-GF
Non-return valve (Threaded versions only)	PPO, EPDM, stainless steel
Sensors	PPS, EPDM, corrosion-resistant coating

**Cavitation risk**

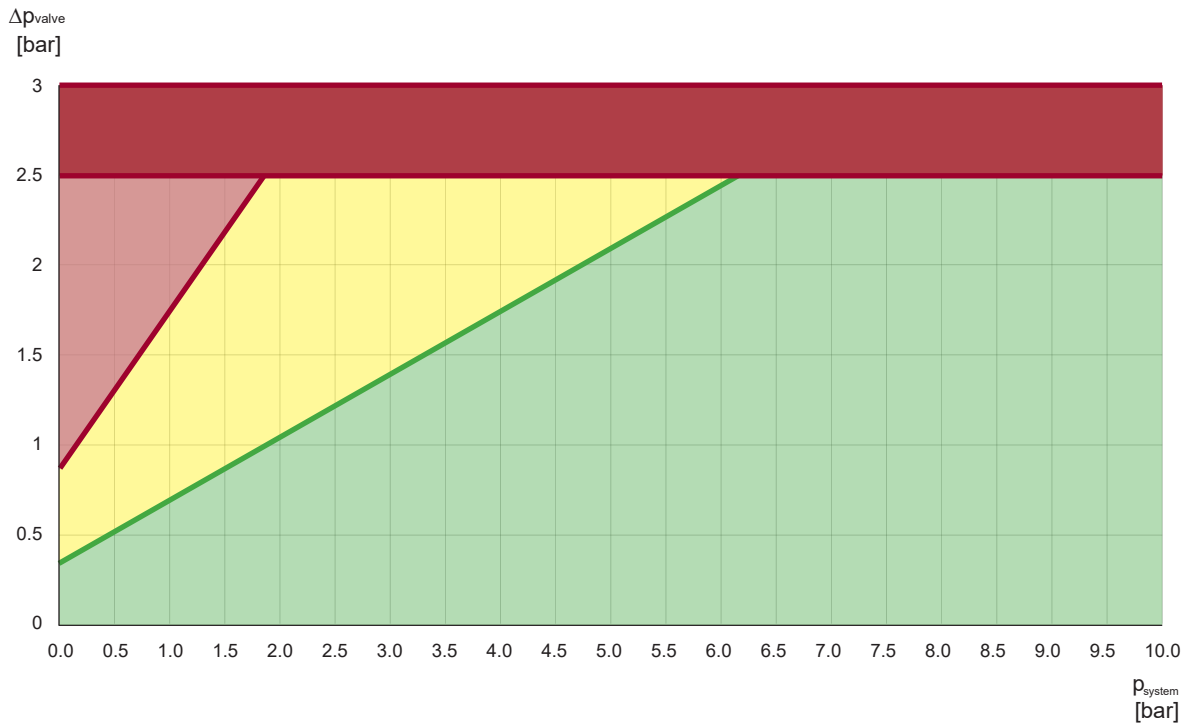

TM073275

*Cavitation risk in a system with a liquid temperature of 20 °C. Y axis: Differential pressure [bar]. X axis: Static pressure, relative [bar].*

Colored area	Description
Green	No or very low risk of cavitation
Yellow	Risk of cavitation
Light red	Cavitation
Dark red	The differential pressure must not exceed 2.5 bar.

As a rule of thumb, the relative static pressure must be at least 3 times the differential pressure across any valve in the system. According to the figure above, cavitation is present in the light red area, while the dark red area is out of specification. Stay clear of the red areas and carefully consider avoiding the yellow area. The risk of cavitation increases with the temperature, and thus the static pressure must be adjusted accordingly.

Valve characteristics

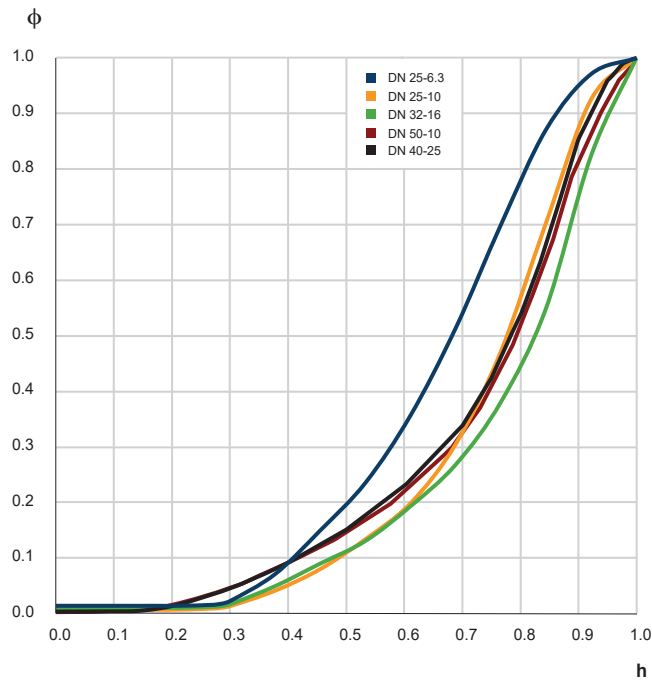

TM07383

Inherent flow characteristic for A-AB in modified equal percentage. X-axis: Relative travel,  $h$ . Y-axis: Relative flow coefficient,  $\Phi$ .

Inherent flow characteristic A-AB	Modified equal percentage (tested according to EN 60534-2-4 and VDI/VDE 2173)
Inherent flow characteristic B-AB, three-way function	Modified equal percentage (tested according to EN 60534-2-4 and VDI/VDE 2173)
Inherent flow characteristic B-AB, two-way function	Fully open
Inherent rangeability A-AB	> 150 (tested according to EN 60534-2-4 and VDI/VDE 2173)

# 11. Dimensions

Threaded version

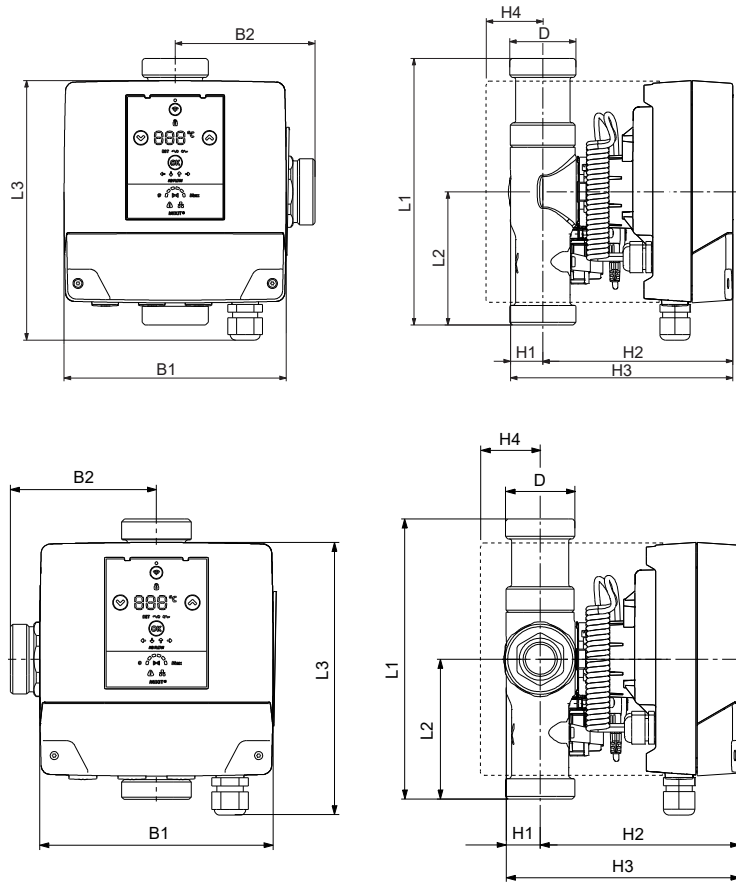

TM073144

TM080464

Dimensions [mm]

MIXIT type	D [inch]	L1	L2	L3	B1	B2	H1	H2	H3	H4	Net weight [kg]	Gross weights [kg]	Ship. vol. [m <sup>3</sup> ]
25-6.3 L NRV	G 1 1/2	240	120	233	200	125	26	168	194	60	5.6	6.8	0.032
25-6.3 R NRV	G 1 1/2	240	120	233	200	125	26	168	194	60	5.6	6.8	0.032
25-10 L NRV	G 1 1/2	240	120	233	200	125	26	168	194	60	5.6	6.8	0.032
25-10 R NRV	G 1 1/2	240	120	233	200	125	26	168	194	60	5.6	6.8	0.032
32-16 L NRV	G 2	240	120	233	200	125	29	171	200	57	6.2	7.4	0.032
32-16 R NRV	G 2	240	120	233	200	125	29	171	200	57	6.2	7.4	0.032

Flange version, DN 32

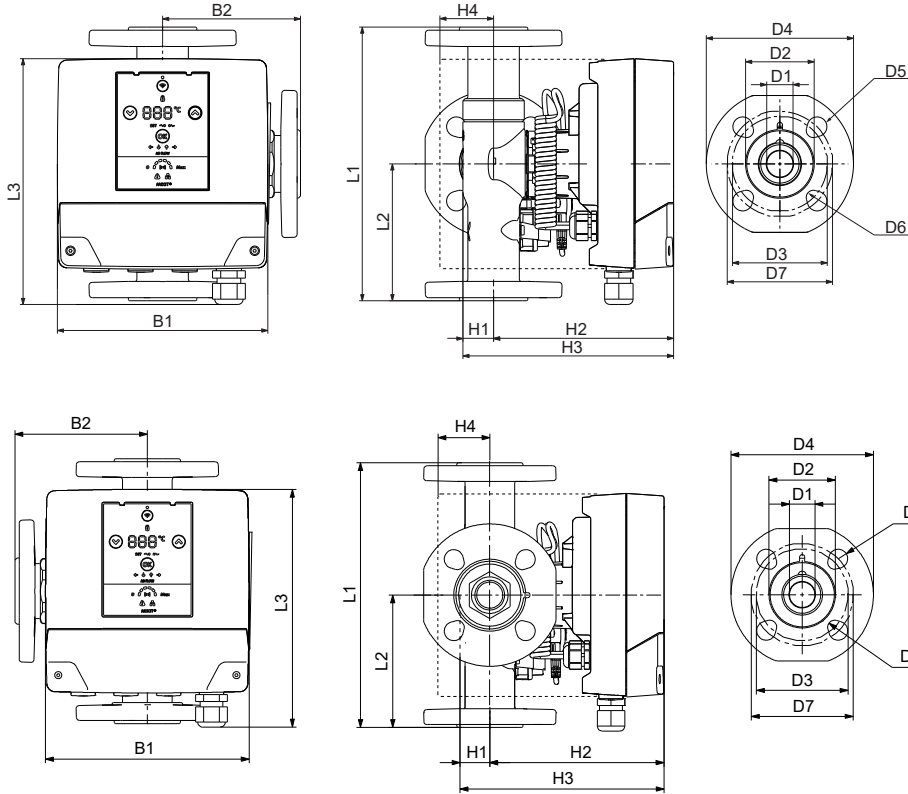

TM073161

TM080442

Dimensions [mm]

MIXIT type	L1	L2	L3	B1	B2	H1	H2	H3	H4	D1	D2	D3	D4	D5	D6	D7	Net weight [kg]	Gross weights [kg]	Ship. vol. [m <sup>3</sup> ]
32-16 L F	270	135	233	200	135	29	171	200	65	25	65	90	140	19	14	100	14.5	15.5	0.032
32-16 R F	270	135	233	200	135	29	171	200	65	25	65	90	140	19	14	100	14.5	15.5	0.032

Flange version, DN 40 and DN 50

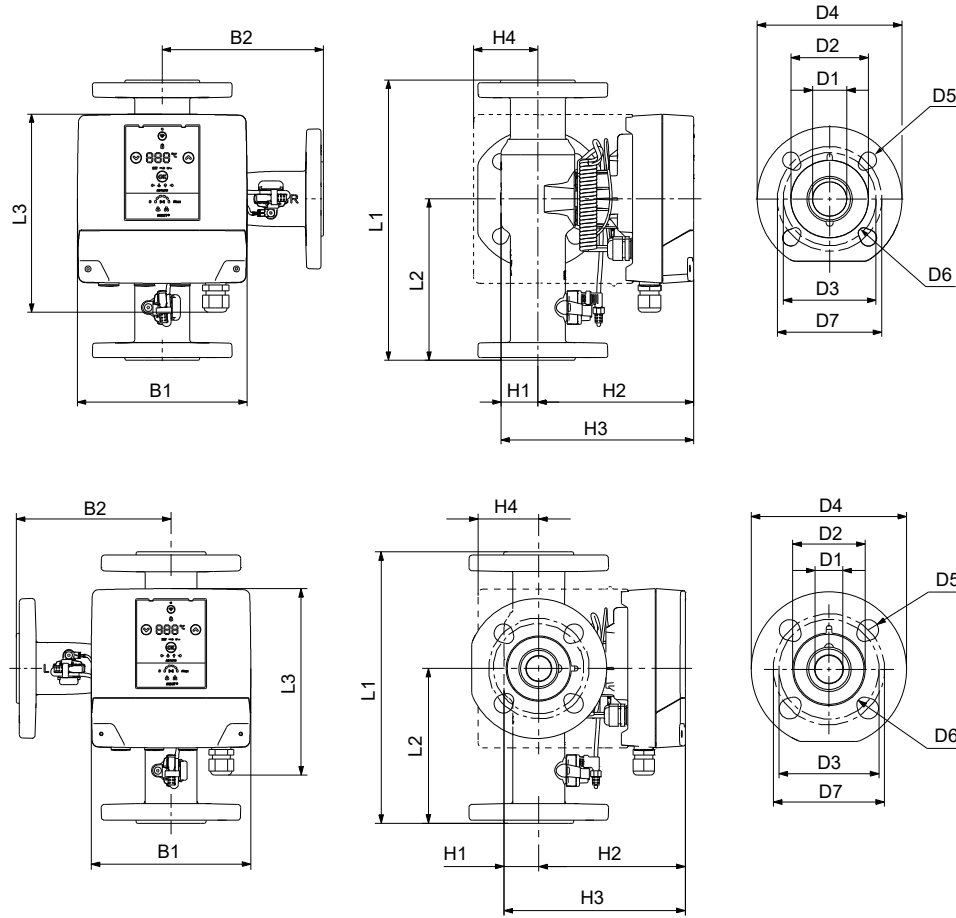

TM080051

TM080589

Dimensions [mm]

MIXIT type	L1	L2	L3	B1	B2	H1	H2	H3	H4	D1	D2	D3	D4	D5	D6	D7	Net weight [kg]	Gross weights [kg]	Ship. vol. [m <sup>3</sup> ]
40-25 L F	330	190	233	200	190	36	176	212	70	32	78	100	150	18	12	110	17.8	18.8	0.050
40-25 R F	330	190	233	200	190	36	176	212	70	32	78	100	150	18	12	110	17.8	18.8	0.050
50-40 L F	330	190	233	200	190	43	184	227	76	40	88	110	165	19	13	125	21.5	22.5	0.050
50-40 R F	330	190	233	200	190	43	184	227	76	40	88	110	165	19	13	125	21.5	22.5	0.050

## 12. Accessories

### Insulating shells

Insulating shells for heating and cooling systems are supplied with the product, but can also be ordered as an accessory.

Insulating shells	Product number
DN 25 thread	99566203
DN 32 thread	99566205
DN 32 flange	99566207
DN 40 flange	99566208
DN 50 flange	99566210

### Non-return valve

Threaded versions of MIXIT, DN 25-32, are fitted with a non-return valve from factory.

For flange versions, DN32-50, non-return valves are fitted externally at the B-port of the MIXIT unit. The non-return valve have to fit the actually DN size.

Non-return valve kit	Product number
DN 25	99566115
DN 32	99566119

### Temperature protection switch

To provide a thermal protection in the system, a temperature protection switch can be installed. Once the temperature of 50 °C is reached, the temperature switch activates the input terminal of the MIXIT unit causing the valve to close.

Product	Supplier	Switching temperature [°C]	Product number
Temperature switch	JUMO	50	99113180

### Temperature sensor



TM072917

ESM-11 sensor

Sensor	Type	Supplier	Measuring range [°C]	Output signal	Product number
Temperature sensor, outside pipe	ESM-11	Danfoss	0 to 100	Pt1000	99113176

#### Related information

[Temperature control](#)

### Outdoor temperature sensors

An outdoor temperature sensor can be fitted to make use of the **Weather curve** and **Warm-weather shutdown** functionalities, in which MIXIT automatically adjusts the mixed flow temperature to the actual temperature outside. The ESMT sensor is used for single MIXIT systems. If the signal is to be shared between several MIXIT units, use a DOL 114 RH/T sensor or JUMO type 902520 sensor.



TM072916

Left to right: ESMT and DOL 114 RH/T sensor

Sensor	Type	Supplier	Measuring range [°C]	Output signal	Product number
Outdoor temperature sensor	ESMT	Danfoss	-30 to +50	Pt1000	99113175
Outdoor temperature sensor	DOL 114 RH/T	Dol Sensors	-40 to +60	0 - 10 V	99113183



TM086654

JUMO type 902520 sensor

Sensor	Type	Supplier	Measuring range [°C]	Output signal	Product number
Outdoor temperature sensor	902520	JUMO	-40 to +50	0 - 10 V	93099391

#### Radiation shield

A radiation shield is available for the DOL 114 sensor. The shield protects the sensor from rain and radiated heat.

Product	Supplier	Product number
Radiation shield for DOL 114	Dol Sensors	99113181

# Thread-thread adapters

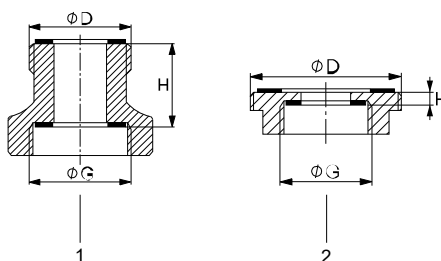

TM072904

New connection G	Union nut connection D	Adapter length [mm] H	Adapter type	Pos.	Material	Product number
G 1 1/2	G 1 1/2	1 x 70	A 4	1	Cast iron (GG)	535043
G 1 1/2	G 1 1/2	1 x 25	A 5	1	Cast iron (GG)	535044
G 1 1/2	G 2	2 x 0	A 6	2	Brass (Ms)	535045
G 1 1/2	G 2	2 x 5	A 7	2	Bronze (Rg)	535046
G 1 1/2	G 2	2 x 35	A 8	1	Cast iron (GG)	535047
G 2	G 2	1 x 20	A 9	1	Bronze (Rg)	535048
G 2	G 2	1 x 26	A 10	1	Cast iron (GG)	535049
G 2	G 2	1 x 70	A 11	1	Cast iron (GG)	535050

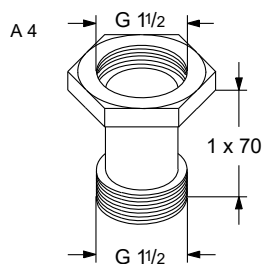

TM072957

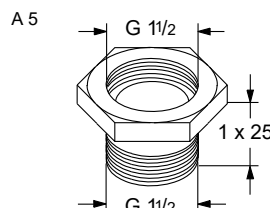

TM072958

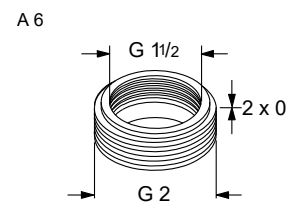

TM072959

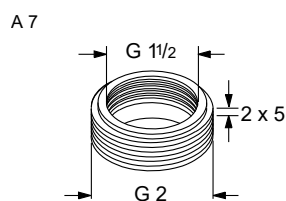

TM072960

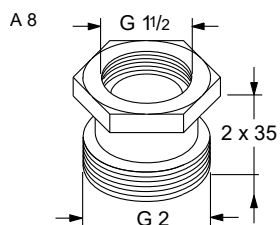

TM072961

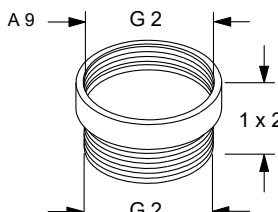

TM072962

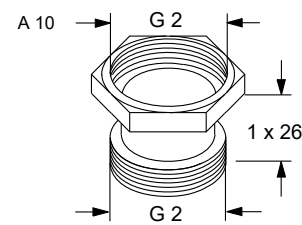

TM072963

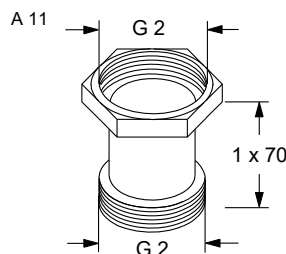

TM072964

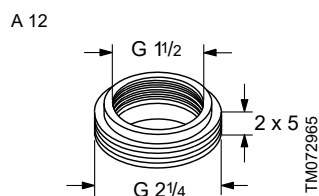

TM072965

### Thread types

G-threads have a cylindrical form in accordance with EN-ISO 228-1 standard.

R-threads have a conical form in accordance with ISO 7-1 standard.

In case the thread size is, for example, 1 1/2", the threads are specified as G 1 1/2 or R 1 1/2. Male G-threads (cylindrical) can only be screwed into female G-threads. Male R-threads (conical) can be screwed into female G or R-threads.

### Thread-flange adapters

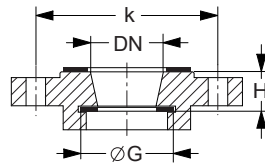

TM060450

New connection G	Flange connection DN	Adapter length H [mm]	k [mm]	Adapter type	Material	Product number PN 6	Product number PN 10
G 1 1/2	DN 32	2 x 20	90	A 14	Cast iron (GG)	535053	
G 1 1/2	DN 40	2 x 20	100	A 17	Cast iron (GG)	535056	
G 1 1/2	DN 50	1 x 20	110	A 19	Cast iron (GG)	535058	
G 2	DN 32	2 x 20	90	A 15	Cast iron (GG)	535054	
G 2	DN 40	2 x 20	100	A 18	Cast iron (GG)	98614387	
G 2	DN 50	2 x 20	110	A 20	Cast iron (GG)	98614411	

A 14

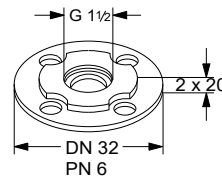

TM072970

A 15

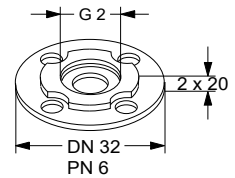

TM072971

A 17

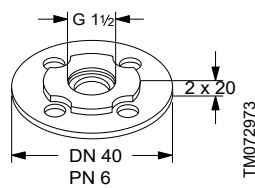

TM072973

A 18

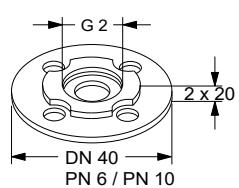

TM072974

A 19

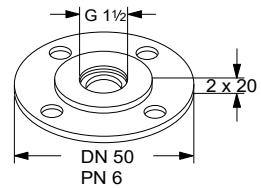

TM072975

A 20

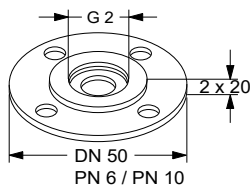

TM072976

A 22

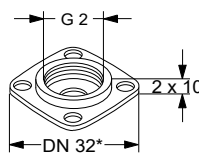

TM072977

A 28

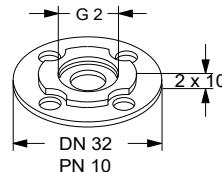

TM072978

# Flange-flange adapters

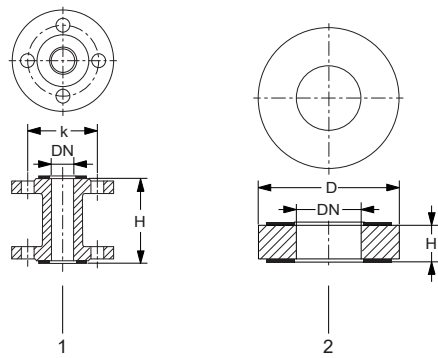

TM072905

New connection DN	Adapter length H [mm]	k		D		Adapter type	Pos.	Material	Product number PN 6	Product number PN 10
		[mm] PN 6	[mm] PN 10	[mm] PN 6	[mm] PN 10					
DN 40	1 x 70	100	110			A 40-70	2	Cast iron (GG)	539921	539721
DN 40	1 x 30			82	88	A 40-30	1	Steel	96281076	96608515
DN 50	1 x 10			90	102	A 50-10	1	Cast iron (GG)	549921	549821
DN 50	1 x 20			90	102	A 50-20	1	Cast iron (GG)	549922	549822
DN 50	1 x 40			90	102	A 50-40	1	Steel	96281077	96608516
DN 50	1 x 50			90	102	A 50-50	1	Cast iron (GG)	549923	549823
DN 50	1 x 60	110	125			A 50-60	2	Cast iron (GG)	549924	549824
DN 65	1 x 10			110	122	A 65-10	1	Cast iron (GG)	559921	559821
DN 65	1 x 25			110	122	A 65-25	1	Cast iron (GG)	559922	559822
DN 65	1 x 160	130	145			A 65-160	2	Steel (St)	559923	559823

A 40-30

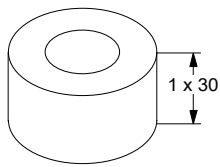

TM072979

A 40-70

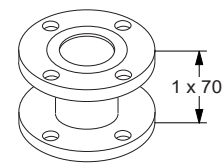

TM072980

A 50-10

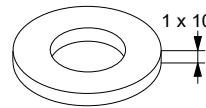

TM072981

A 50-20

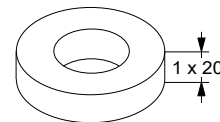

TM072982

A 50-40

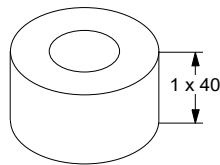

TM072983

A 50-50

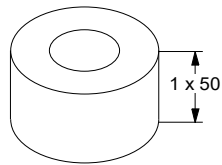

TM072984

A 50-60

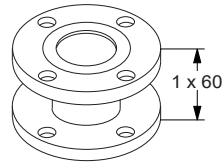

TM072985

A 65-10

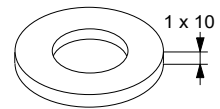

TM072986

A 65-25

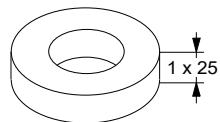

TM072987

A 65-160

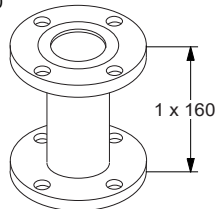

TM072988

DN 65/50 flange adapters

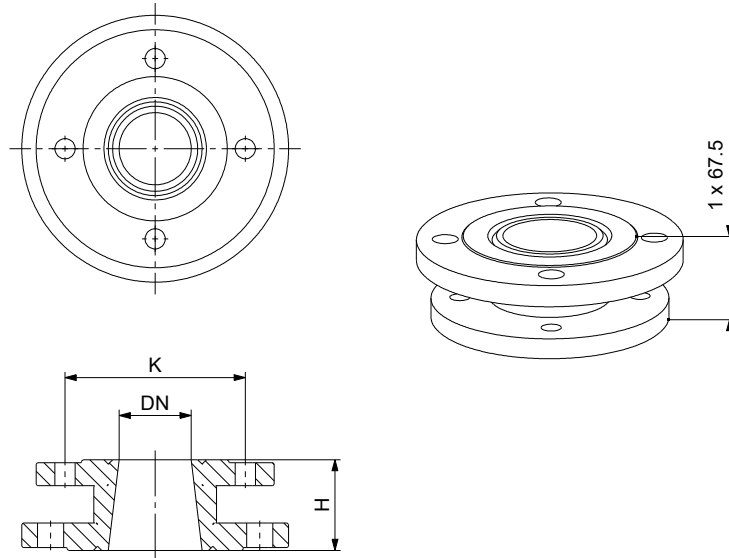

TM081935

New connection DN	Adapter length H [mm]	k [mm]	Adapter type	Material	Product number PN 10
DN 65/50	1 x 65.5	125	A 65-50	Steel	96497649

## 13. Product numbers

When ordering a complete MIXIT system, you are required to select a MIXIT valve unit variant and a compatible pump. For more information, see the sections on performance range and compatible pumps.

Choose between these MIXIT valve unit variants:

- MIXIT
- MIXIT DYNAMIC



You can upgrade MIXIT to DYNAMIC at any time. The MIXIT DYNAMIC variant is delivered with the DYNAMIC upgrade installed from factory. Both variants can be upgraded to CONNECT at any time via Grundfos GO Remote.

Choose between these Grundfos pumps:

- MAGNA3 single-head
- MAGNA3 twin-head
- TPE3 single-head
- TPE3 twin-head

### Related information

- [2. Performance range](#)
- [Compatible pumps](#)

## MIXIT valve unit

Valve unit	Product number	
	PN 10	PN 6/10
MIXIT 25-6.3 L NRV	99508816	
MIXIT 25-6.3 R NRV	99508818	
MIXIT 25-10 L NRV	99508819	
MIXIT 25-10 R NRV	99508820	
MIXIT 32-16 L NRV	99508822	
MIXIT 32-16 R NRV	99508834	
MIXIT 32-16 L F		99508836
MIXIT 32-16 R F		99508837
MIXIT 40-25 L F		99508838
MIXIT 40-25 R F		99508839
MIXIT 50-40 L F		99508840
MIXIT 50-40 R F		99508841
MIXIT DYNAMIC 25-6.3 L NRV	99524563	
MIXIT DYNAMIC 25-6.3 R NRV	99524667	
MIXIT DYNAMIC 25-10 L NRV	99524668	
MIXIT DYNAMIC 25-10 R NRV	99524669	
MIXIT DYNAMIC 32-16 L NRV	99524670	
MIXIT DYNAMIC 32-16 R NRV	99524671	
MIXIT DYNAMIC 32-16 L F		99524683
MIXIT DYNAMIC 32-16 R F		99524684
MIXIT DYNAMIC 40-25 L F		99524685
MIXIT DYNAMIC 40-25 R F		99524686
MIXIT DYNAMIC 50-40 L F		99524687
MIXIT DYNAMIC 50-40 R F		99524688

### Abbreviations:

L: Left-oriented B port.

R: Right-oriented B port.

NRV: Non-return valve included.

DYNAMIC: The DYNAMIC upgrade is installed from factory.

F: Flange pipe connection type.

### Related information

[Type key](#)

## Upgrades

Upgrade	Product number
DYNAMIC, 1 licence (box)	99558420
DYNAMIC, 1 licence (digital)	99725067
DYNAMIC, 5 licences (digital)	99725068
CONNECT, 1 licence (box)	99558443
CONNECT, 1 licence (digital)	99725069
CONNECT, 5 licences (digital)	99725070

**MAGNA3 single-head pumps**

Pump type	Product number	
	PN 10	PN 6/10
Threaded connection		
MAGNA3 25-40	97924244	
MAGNA3 25-60	97924245	
MAGNA3 25-80	97924246	
MAGNA3 25-100	97924247	
MAGNA3 25-120	97924248	
MAGNA3 32-40	97924254	
MAGNA3 32-60	97924255	
MAGNA3 32-80	97924256	
MAGNA3 32-100	97924257	
MAGNA3 32-120	98609707	

Pump type	Product number	
	PN 10	PN 6/10
Flanged connection		
MAGNA3 32-40 F		98333834
MAGNA3 32-60 F		98333854
MAGNA3 32-80 F		98333874
MAGNA3 32-100 F		97924258
MAGNA3 32-120 F		97924259
MAGNA3 40-40 F		97924266
MAGNA3 40-60 F		97924267
MAGNA3 40-80 F		97924268
MAGNA3 40-100 F		97924269
MAGNA3 40-120 F		97924270
MAGNA3 40-150 F		97924271
MAGNA3 40-180 F		97924272
MAGNA3 50-40 F		97924280
MAGNA3 50-60 F		97924281
MAGNA3 50-80 F		97924282
MAGNA3 50-100 F		97924283
MAGNA3 50-120 F		97924284
MAGNA3 50-150 F		97924285
MAGNA3 50-180 F		97924286
MAGNA3 65-40 F		97924294
MAGNA3 65-60 F		97924295
MAGNA3 65-80 F		97924296
MAGNA3 65-100 F		97924297
MAGNA3 65-120 F		97924298
MAGNA3 65-150 F		97924299

**MAGNA3 twin-head pumps**

Pump type	Product number	
	PN 10	PN 16
Threaded connection		
MAGNA3 D 32-40	97924449	97924455
MAGNA3 D 32-60	97924450	97924456
MAGNA3 D 32-80	97924451	97924457
MAGNA3 D 32-100	97924452	97924458

Pump type	Product number	
	PN 6/10	PN 16
Flanged connection		
MAGNA3 D 32-40 F	98333840	98333838
MAGNA3 D 32-60 F	98333860	98333858
MAGNA3 D 32-80 F	98333880	98333878
MAGNA3 D 32-100 F	97924453	97924459
MAGNA3 D 32-120 F	97924454	97924460
MAGNA3 D 40-40 F	97924461	97924468
MAGNA3 D 40-60 F	97924462	97924469
MAGNA3 D 40-80 F	97924463	97924470
MAGNA3 D 40-100 F	97924464	97924471
MAGNA3 D 40-120 F	97924465	97924472
MAGNA3 D 40-150 F	97924466	97924473
MAGNA3 D 40-180 F	97924467	97924474
MAGNA3 D 50-40 F	97924475	97924482
MAGNA3 D 50-60 F	97924476	97924483
MAGNA3 D 50-80 F	97924477	97924484
MAGNA3 D 50-100 F	97924478	97924485
MAGNA3 D 50-120 F	97924479	97924486
MAGNA3 D 50-150 F	97924480	97924487
MAGNA3 D 50-180 F	97924481	97924488
MAGNA3 D 65-40 F	97924489	97924495
MAGNA3 D 65-60 F	97924490	97924496
MAGNA3 D 65-80 F	97924491	97924497
MAGNA3 D 65-100 F	97924492	97924498
MAGNA3 D 65-120 F	97924493	97924499
MAGNA3 D 65-150 F	97924494	97924500

## MAGNA3 single-head pumps for the German market

Pump type	Product number	
	PN 10	PN 6/10
Threaded connection		
MAGNA3 25-40	97924623	
MAGNA3 25-60	97924624	
MAGNA3 25-80	97924625	
MAGNA3 25-100	97924626	
MAGNA3 25-120	97924627	
MAGNA3 32-40	97924633	
MAGNA3 32-60	97924634	
MAGNA3 32-80	97924635	
MAGNA3 32-100	97924636	
MAGNA3 32-120	98609708	

Pump type	Product number	
	PN 10	PN 6/10
Flanged connection		
MAGNA3 32-40 F		98333835
MAGNA3 32-60 F		98333855
MAGNA3 32-80 F		98333875
MAGNA3 32-100 F		97924637
MAGNA3 32-120 F		97924638
MAGNA3 40-40 F		97924645
MAGNA3 40-60 F		97924646
MAGNA3 40-80 F		97924647
MAGNA3 40-100 F		97924648
MAGNA3 40-120 F		97924649
MAGNA3 40-150 F		97924650
MAGNA3 40-180 F		97924651
MAGNA3 50-40 F		97924659
MAGNA3 50-60 F		97924660
MAGNA3 50-80 F		97924661
MAGNA3 50-100 F		97924662
MAGNA3 50-120 F		97924663
MAGNA3 50-150 F		97924664
MAGNA3 50-180 F		97924665
MAGNA3 65-40 F		97924674
MAGNA3 65-60 F		97924675
MAGNA3 65-80 F		97924676
MAGNA3 65-100 F		97924677
MAGNA3 65-120 F		97924678
MAGNA3 65-150 F		97924679

## MAGNA3 twin-head pumps for the German market

Pump type	Product number	
	PN 10	PN 16
Threaded connection		
MAGNA3 D 32-40	97924829	97924835
MAGNA3 D 32-60	97924830	97924836
MAGNA3 D 32-80	97924831	97924837
MAGNA3 D 32-100	97924832	97924838

Pump type	Product number	
	PN 6/10	PN 16
Flanged connection		
MAGNA3 D 32-40 F	98333841	98333839
MAGNA3 D 32-60 F	98333861	98333859
MAGNA3 D 32-80 F	98333881	98333879
MAGNA3 D 32-100 F	97924833	97924839
MAGNA3 D 32-120 F	97924834	97924840
MAGNA3 D 40-40 F	97924841	97924848
MAGNA3 D 40-60 F	97924842	97924849
MAGNA3 D 40-80 F	97924843	97924850
MAGNA3 D 40-100 F	97924844	97924851
MAGNA3 D 40-120 F	97924845	97924852
MAGNA3 D 40-150 F	97924846	97924853
MAGNA3 D 40-180 F	97924847	97924854
MAGNA3 D 50-40 F	97924855	97924862
MAGNA3 D 50-60 F	97924856	97924863
MAGNA3 D 50-80 F	97924857	97924864
MAGNA3 D 50-100 F	97924858	97924865
MAGNA3 D 50-120 F	97924859	97924866
MAGNA3 D 50-150 F	97924860	97924867
MAGNA3 D 50-180 F	97924861	97924868
MAGNA3 D 65-40 F	97924869	97924875
MAGNA3 D 65-60 F	97924870	97924876
MAGNA3 D 65-80 F	97924871	97924877
MAGNA3 D 65-100 F	97924872	97924878
MAGNA3 D 65-120 F	97924873	97924879
MAGNA3 D 65-150 F	97924874	97924880

**TPE3 single-head pumps**

Pump type	Product number
TPE3 32-80	
TPE3 32-120	
TPE3 32-150	
TPE3 32-180	
TPE3 32-200	
TPE3 40-80	
TPE3 40-120	
TPE3 40-150	
TPE3 40-180	
TPE3 40-200	
TPE3 40-240	
TPE3 50-60	See Grundfos Product Center: <a href="http://product-selection.grundfos.com">http://product-selection.grundfos.com</a>
TPE3 50-80	
TPE3 50-120	
TPE3 50-150	
TPE3 50-180	
TPE3 50-200	
TPE3 50-240	
TPE3 65-60	
TPE3 65-80	
TPE3 65-120	
TPE3 65-150	
TPE3 65-180	
TPE3 65-200	

**TPE3 twin-head pumps**

Pump type	Product number
TPE3 D 32-80	
TPE3 D 32-120	
TPE3 D 32-150	
TPE3 D 32-180	
TPE3 D 32-200	
TPE3 D 40-80	
TPE3 D 40-120	
TPE3 D 40-150	
TPE3 D 40-180	
TPE3 D 40-200	
TPE3 D 40-240	
TPE3 D 50-60	See Grundfos Product Center: <a href="http://product-selection.grundfos.com">http://product-selection.grundfos.com</a>
TPE3 D 50-80	
TPE3 D 50-120	
TPE3 D 50-150	
TPE3 D 50-180	
TPE3 D 50-200	
TPE3 D 50-240	
TPE3 65-60	
TPE3 65-80	
TPE3 65-120	
TPE3 65-150	
TPE3 65-180	
TPE3 65-200	

## 14. Technical terms

Actuator	An actuator controls the opening of a valve via a control signal. MIXIT has a built in actuator in its control box.
A port	Port on the MIXIT unit.
AB port	Port on the MIXIT unit. The mixed liquid from the A and B port is led out through the AB port.
BACnet	BACnet is a communications protocol for building, automation and controls network. The protocol governs how devices across building automation systems work together.
Ball valve	A hollow ball, which is used to control the flow through it. The ball valve in MIXIT can be configured both as a two-way valve and a three-way valve. MIXIT changes between the two simply by changing the opening direction of the ball valve.
Bluff body	When a bluff body is placed inside a pipe, a series of vortices will be generated on either side of the bluff body. These vortices propagate downstream, giving rise to periodic pressure variations which can be detected by the flow sensor. The frequency of the pressure variations is proportional to the volume flow through the pipe.
B port	Port on the MIXIT unit. The return liquid from the system is led back into the loop via the B port.
B-port orientation	The B port on a MIXIT unit will either be on the left or right side of the valve.
Building Management System (BMS)	A Building Management System (BMS) is a control system that controls and monitors a building's systems such as heating and ventilation. A BMS typically uses protocols such as BACnet and Modbus.
Controller	Using sensor inputs a controller holds the liquid temperature at a specified temperature setpoint. In MIXIT the controller is integrated.
Delta T ( $\Delta T$ )	Delta T ( $\Delta T$ ) is the temperature difference between the supply and return liquid in a heating or cooling system.
Fieldbus	Fieldbus is a two-way communication link between devices. Fieldbus is integrated into the MIXIT unit and act as the link between MIXIT and a Building Management System. MIXIT provides all data points through one data connection and no I/O is required in the sub controller. If the integrator uses an IP-based fieldbus, the sub controller is redundant.
Firmware	Firmware is software integrated in a hardware device. The firmware is specifically designed for that piece of hardware and acts as the operating system.
Flow	Flow is the amount of liquid that passes through a pump within a certain period of time. Volume flow (Q) is the amount of liquid, the pump can move per unit time ( $m^3/h$ ).
Flow temperature	The temperature of the liquid in the supply pipe in a heating or cooling system.
GENIbus	GENIbus is an open data communication protocol developed and maintained by Grundfos. It is used to connect Grundfos pumps to pump controllers or via gateways to monitoring and supervisory computers in Building Management Systems and SCADA systems.
GLoWPAN	GLoWPAN is a propriatary wireless signal developed and maintained by Grundfos.
Heat load, $\Phi$ [kW]	The amount of heat required by a heating system.
Hydraulic power	The power that the pump transfers to the liquid in the shape of flow and head.
Injection circuit, two-way valve	This injection circuit operates with a variable flow on the primary side and a constant flow on the secondary side. The circuit has a pump installed on the primary side, injecting the liquid into the heating system, while the pump on the secondary side distributes the liquid in the system.
Injection circuit, three-way valve	The injection circuit operates with a constant flow and temperature on the primary side, causing the temperature on the secondary side to increase instantly. The circuit has a pump installed on the primary side, injecting the liquid into the heating system, while the pump on the secondary side distributes the liquid in the system. In a two-way valve injection circuit, the temperature at the mixing point is controlled by opening and closing the valve. In a three-way valve injection circuit, the mixed temperature is controlled by opening and closing port A of the control valve.
$K_v$	$K_v$ represents the valve capacity measured as the flow of liquid in $m^3/h$ at a pressure differential of 1 bar across the valve, with the valve open at any position.
$K_{vs}$	$K_{vs}$ is the maximum $K_v$ value measured when the valve is fully open (100 %). For MIXIT, the $K_{vs}$ value represent the water in $m^3/h$ at a differential pressure of 1 bar from port A to AB. The $K_{vs}$ value can be used to determine the size of a valve.
Mixing circuit	The basic principle of a mixing loop is to mix the primary liquid with the return liquid to obtain the required mix temperature. The mixing circuit operates with a variable flow on the primary side and a constant flow on the secondary side. Because the system in this type of application allows for variable flow, there is no primary pump.
Modbus	Modbus is a communications protocol enabling communication between devices connected to the same network.
Non-return valve	The non-return valve ensures that the liquid flows through the pipe in the correct direction where pressure conditions may otherwise cause a reversed flow.
Integrated Temperature Sensor (ITS)	A temperature sensor integrated in the MIXIT unit.

Secondary flow	The secondary flow refers to the flow in the secondary circuit of a heating or cooling system.
Secondary temperature difference	The temperature difference between the supply and return liquid in the secondary circuit of a heating or cooling system.
Settable flow range	The products working range within which a maximum flow can be set.
Valve position	LEDs on MIXIT's operating panel, indicating to what degree the valve is open.
Vortex flow sensor	A combined flow and temperature sensor integrated in the MIXIT unit.
ENeV	The Energieeinsparverordnung is a regulation in Germany describing minimum requirements regarding energy use of new and renovated buildings.

## 15. Grundfos Product Center

Online search and sizing tool to help you make the right choice.

From the international view, you can select your specific country to view the product range available to you.

International view: <http://product-selection.grundfos.com>

### All the information you need in one place

Performance curves, technical specifications, pictures, dimensional drawings, motor curves, wiring diagrams, spare parts, service kits, 3D drawings, documents, system parts. The Product Center displays any recent and saved items - including complete projects - right on the main page.

### Downloads

On the product pages, you can download installation and operating instructions, data booklets, service instructions, etc., in PDF format.

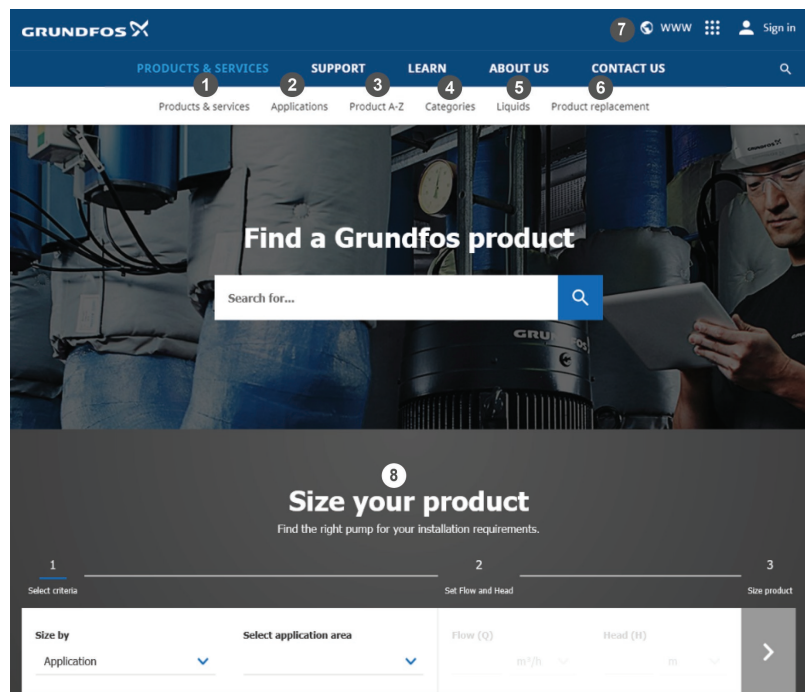
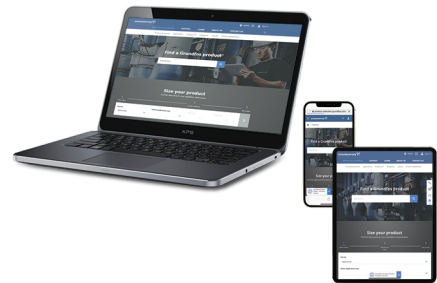

When you select your country, you will see the menus below. Note that some menus may not be available depending on the country.

Example: <https://product-selection.grundfos.com/uk>

Pos.	Description
1	<b>Products &amp; services</b> enables you to find products and documents by typing a product number or name into the search field.
2	<b>Applications</b> enables you to choose an application to see how Grundfos can help you design and optimise your system.
3	<b>Products A-Z</b> enables you to look through a list of all the Grundfos products.
4	<b>Categories</b> enables you to look for a product category.
5	<b>Liquids</b> enables you to find pumps designed for aggressive, flammable or other special liquids.
6	<b>Product replacement</b> enables you to find a suitable replacement.
7	<b>WWW</b> enables you to select the country, which changes the language, the available product range and the structure of the website.
8	<b>Sizing</b> enables you to size a product based on your application and operating conditions.

## 16. Document quality feedback

To provide feedback about this document, scan the QR code using your phone's camera or a QR code app.



FEEDBACK99513565

[Click here to submit your feedback](#)

99513565 11.2024

ECM: 1408339

**GRUNDFOS Holding A/S**  
Poul Due Jensens Vej 7  
DK-8850 Bjerringbro  
Tel: +45 87 50 14 00  
[www.grundfos.com](http://www.grundfos.com)

**GRUNDFOS** 